

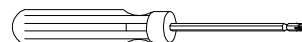









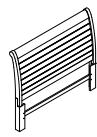



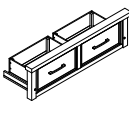



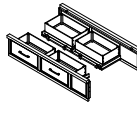



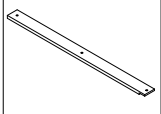

Thank you for purchasing this quality product. Be sure to check all packing material carefully for small parts that may have come loose inside the carton during shipment.

TOOL REQUIRED (NOT PROVIDED):  
PHILLIPS SCREW DRIVER

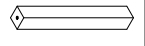

LIST OF HARDWARE				LIST OF PARTS			
No.	Description		Q'ty	No.	Description	Picture	Q'ty
A		Bolt	Φ1/4"*11.5*57mm	4	1		1
		Flat washer	Φ1/4"*18*2mm				
		Spring washer	Φ1/4"*11*2mm				
B		Bolt	Φ1/4"*11.5*32mm	4	2		1
		Flat washer	Φ1/4"*18*2mm				
		Spring washer	Φ1/4"*11*2mm				
C		Bolt	Φ1/4"*11.5*50mm	5	3		2
		Flat washer	Φ1/4"*18*2mm				
		Spring washer	Φ1/4"*11*2mm				
D		Allen Key	4*74*29mm	1	4		1
E		Hex nut	Φ1/4"*10*5mm	4			
F		Wrench	75*12*2mm	1			
G		Spring washer	Φ1/4"*11*2mm	4	5		2
H		Flat washer	Φ1/4"*18*2mm	4			
I		Screw	Φ8*30mm	26			
K		Bolt	Φ1/4"*11.5*32mm	6	7		6
		Flat washer	Φ1/4"*18*2mm				
		Spring washer	Φ1/4"*11*2mm				
8					8		1

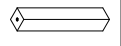
Note:

- No. (A,B,D,E,F,G,H) packed with side rails box.
- No. (C,I,K) packed with footboard box.

Note:

- No. (1) packed with headboard box.
- No. (2,4,5,6,7,8) packed with footboard box.
- No. (3) packed with side rails box.

Thank you for purchasing this quality product. Be sure to check all packing material carefully for small parts that may have come loose inside the carton during shipment.

STEP 1: Take out the drawers of the footboard (2).

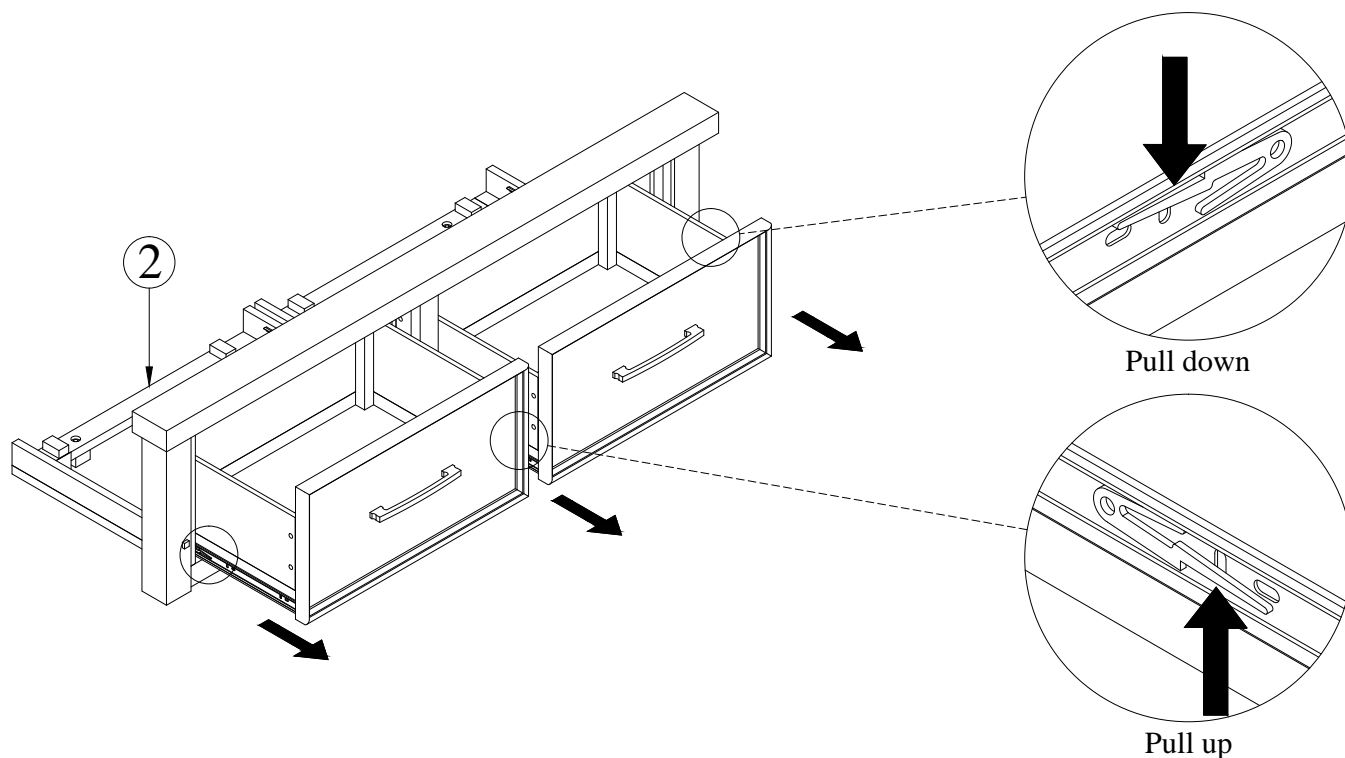

STEP 2: Take out the drawers of the side rail (L / R) (3).

Note: The picture shown below is the left side view. Please do the same way on right side.

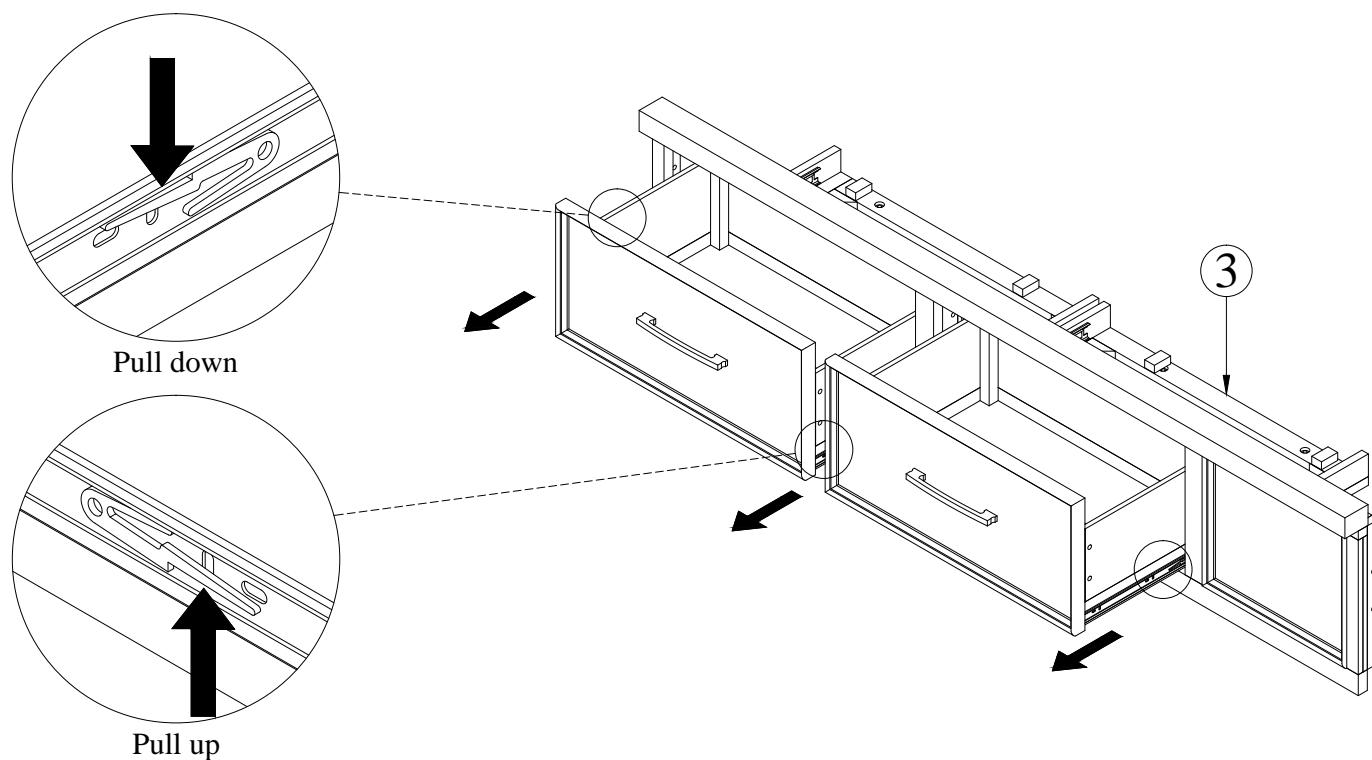

Thank you for purchasing this quality product. Be sure to check all packing material carefully for small parts that may have come loose inside the carton during shipment.

STEP 3: Attach side rail ( L / R ) (3) into headboard (1) by using allen key (D) and bolt, spring washer, flat washer (A), hex nut (E), wrench (F), spring washer (G), flat washer (H).

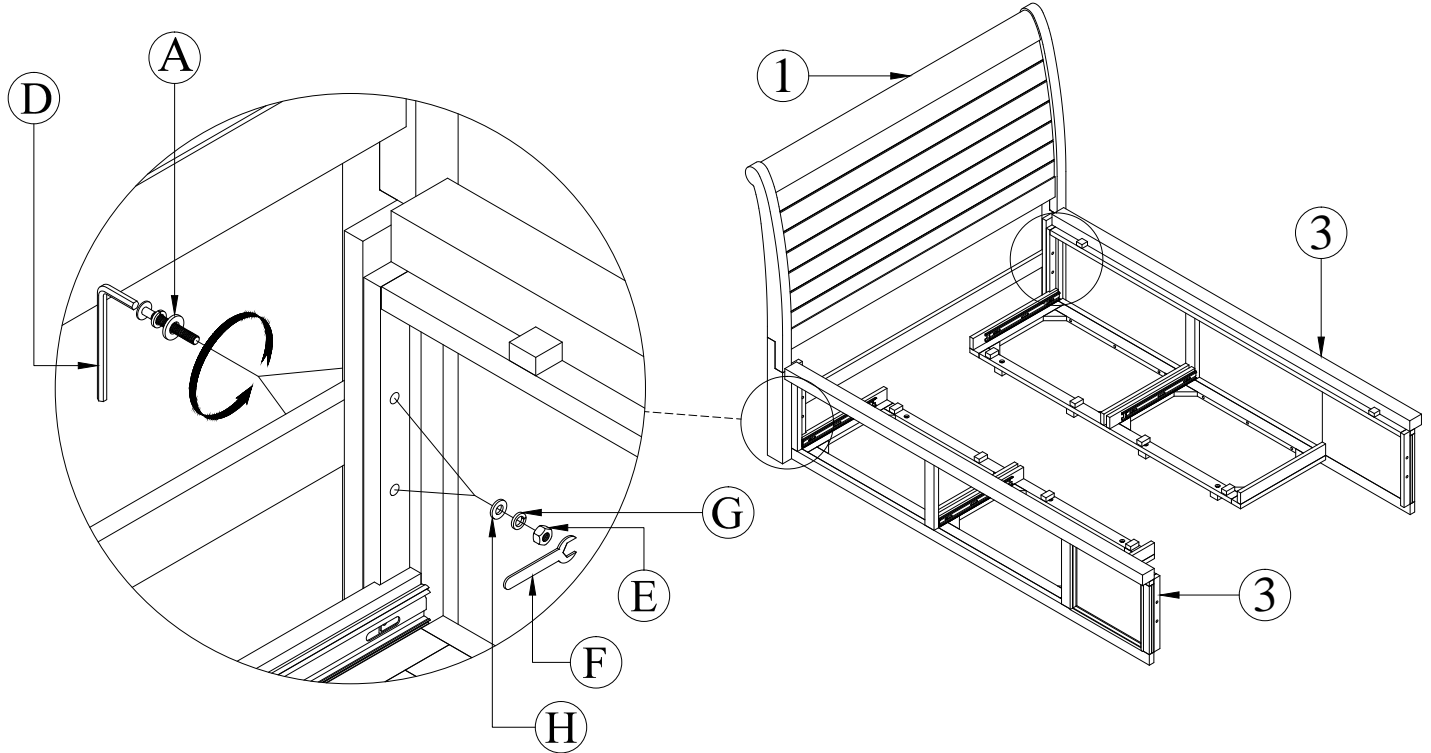

STEP 4: Attach side rail ( L / R ) (3) into footboard (2) by using allen key (D) and bolt, spring washer, flat washer (B).

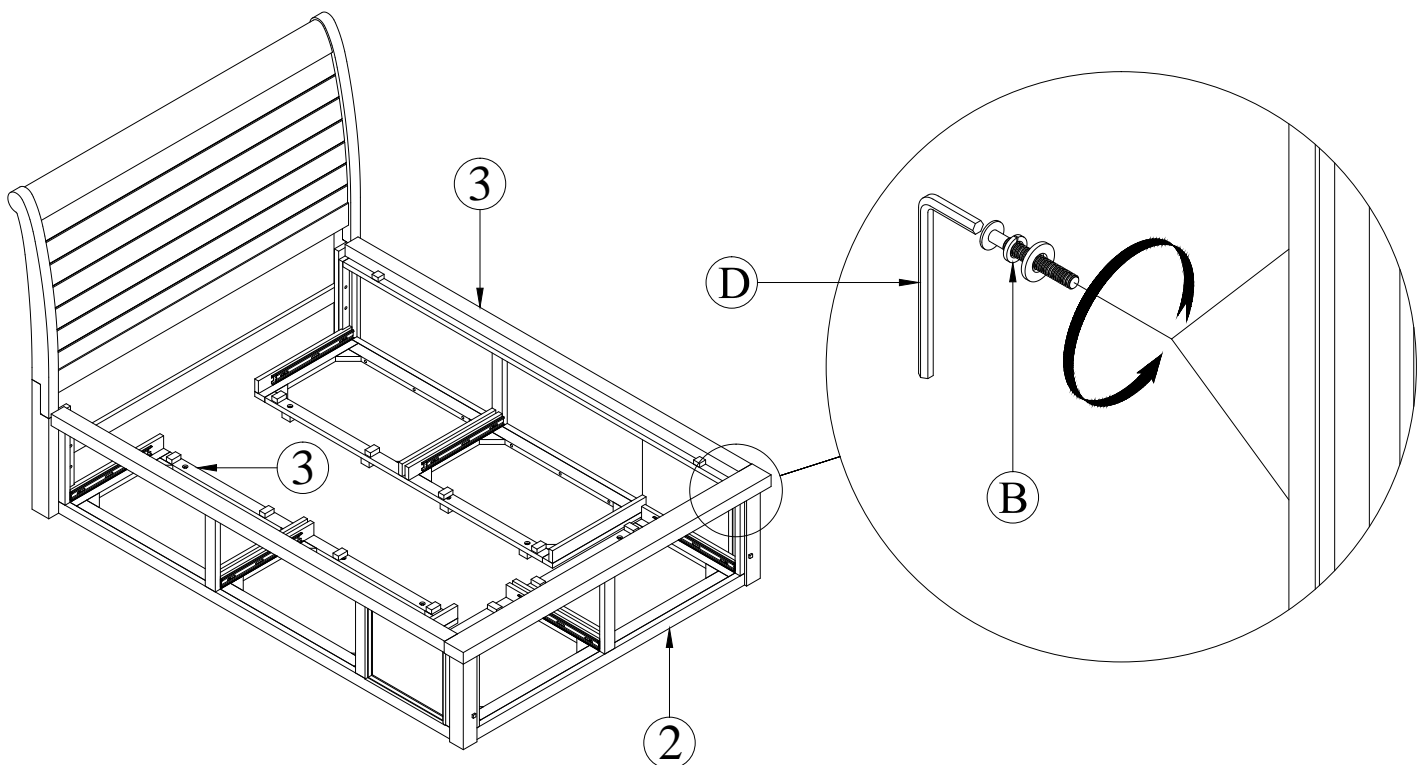

ITEM NO.: 2688-20H / 2678-28USF / 2678-27USR

ITEM NO.: 2681-20H / 2681-28USF / 2681-27USR

ITEM NO.: 2692-20H / 2692-28USF / 2692-27USR

FULL STORAGE BED

Thank you for purchasing this quality product. Be sure to check all packing material carefully for small parts that may have come loose inside the carton during shipment.

STEP 5: Put slat roll (4) on side rail (L/R)(3).

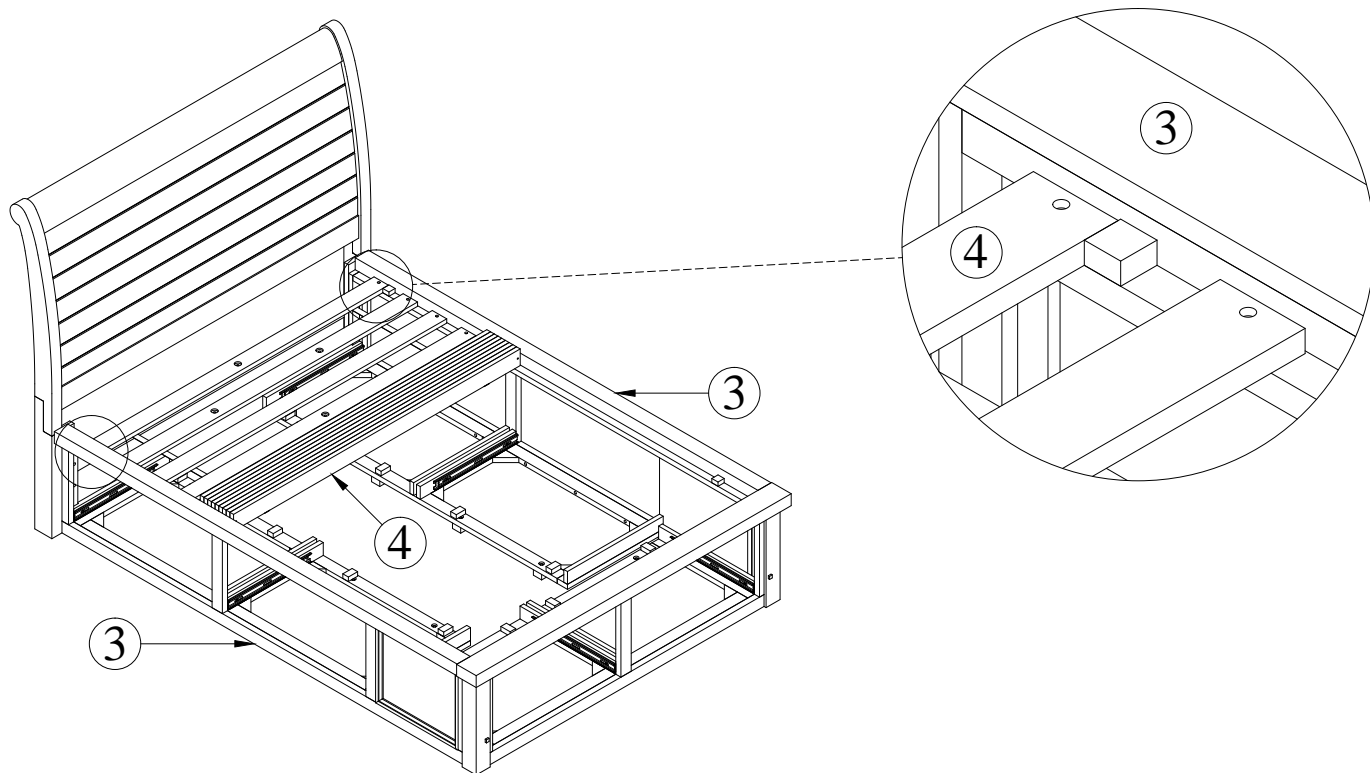

STEP 6: Attach support leg 1 (6) to slat (5) and slat roll (4) by using allen key (D) and bolt, spring washer, flat washer (C).

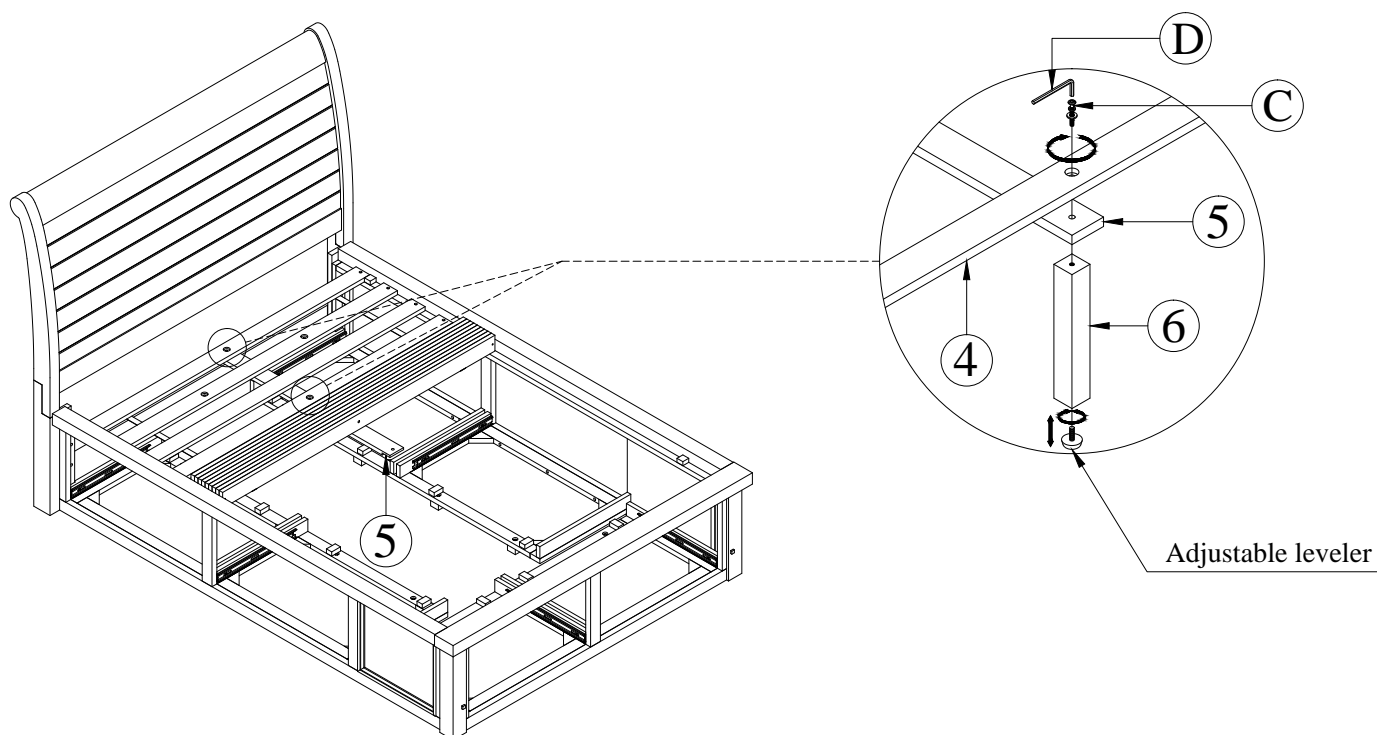

ITEM NO.: 2688-20H / 2678-28USF / 2678-27USR

ITEM NO.: 2681-20H / 2681-28USF / 2681-27USR

ITEM NO.: 2692-20H / 2692-28USF / 2692-27USR

FULL STORAGE BED

Thank you for purchasing this quality product. Be sure to check all packing material carefully for small parts that may have come loose inside the carton during shipment.

STEP 7: Attach support leg 1 (6) to slat (5) and slat roll (4) by using allen key (D) and bolt, spring washer, flat washer (C).

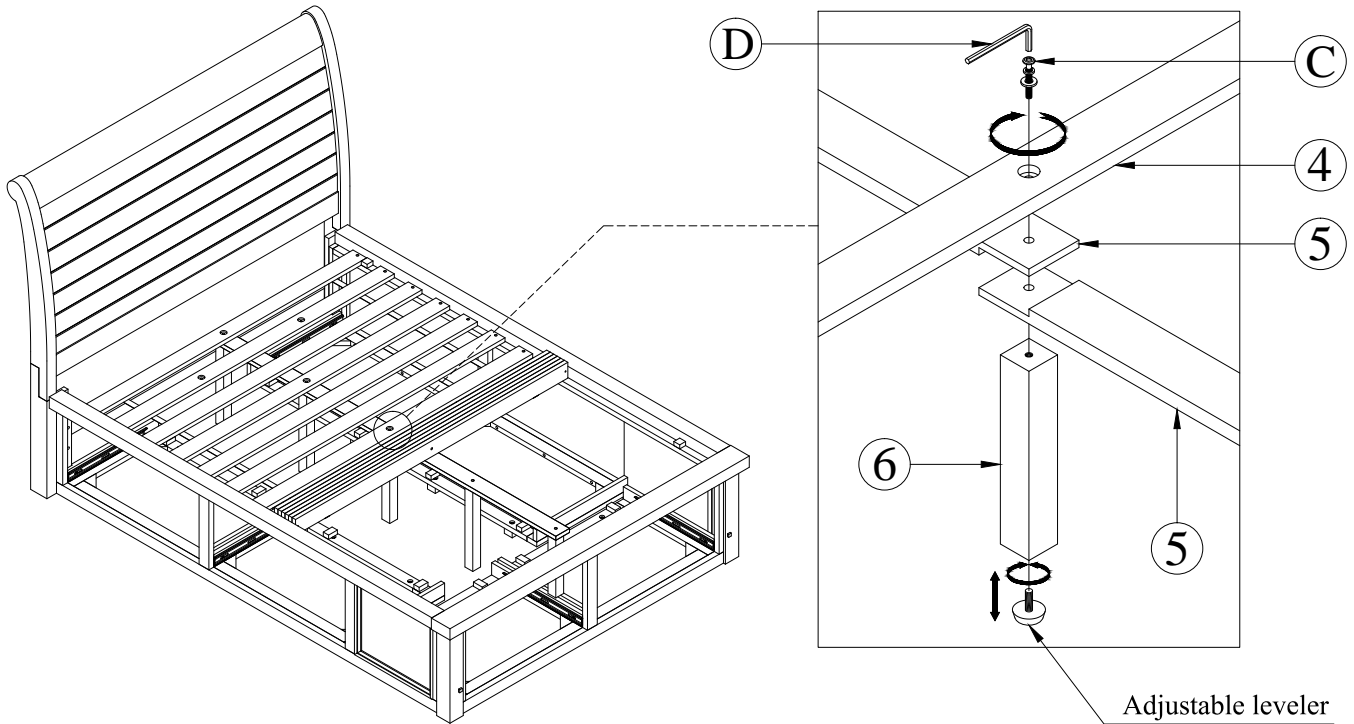

STEP 8: Attach support leg 1 (6), support leg 3 (8) to slat (5) and slat roll (4) by using allen key (D) and bolt, spring washer, flat washer (C).

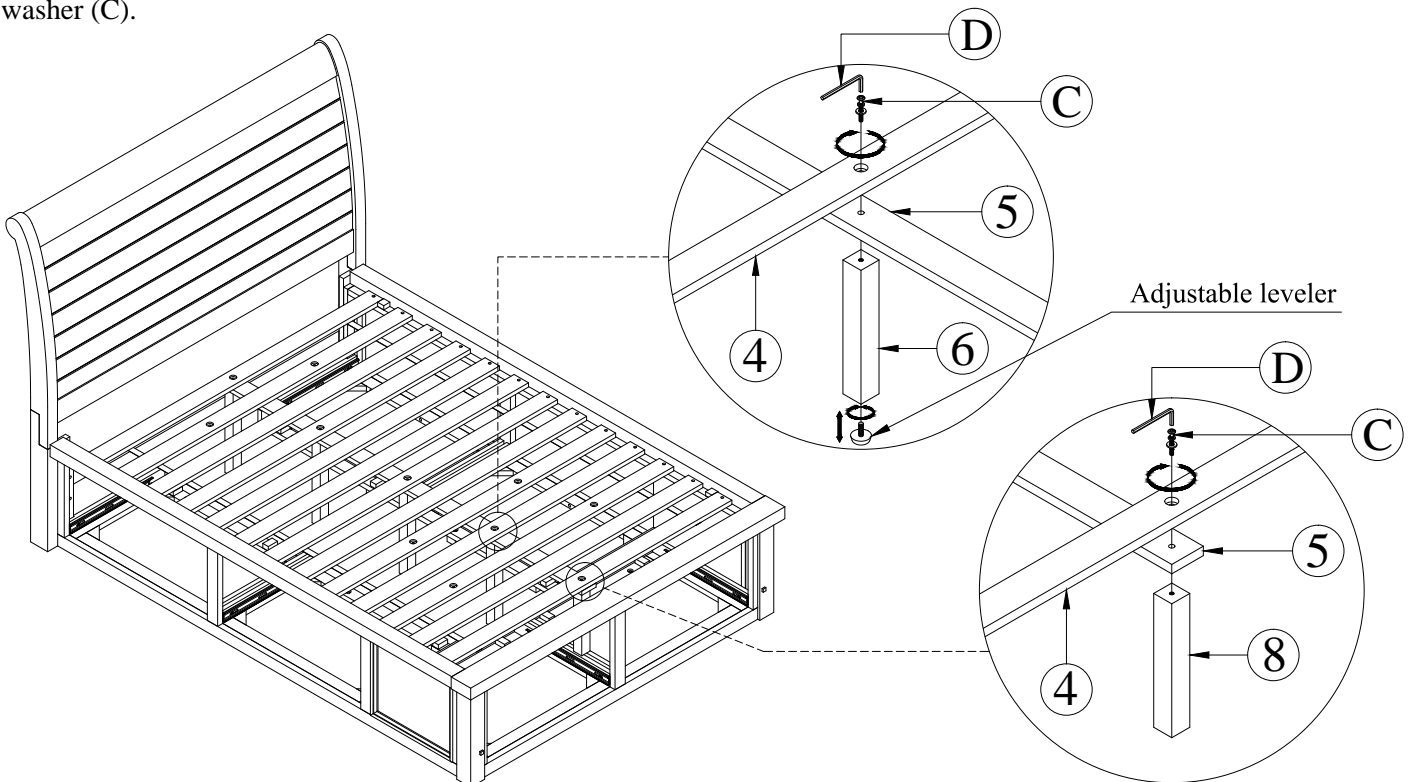

Thank you for purchasing this quality product. Be sure to check all packing material carefully for small parts that may have come loose inside the carton during shipment.

STEP 9: Attach support leg 2 (7) to slat roll (4) by using allen key (D), and bolt, spring washer, flat washer (B).

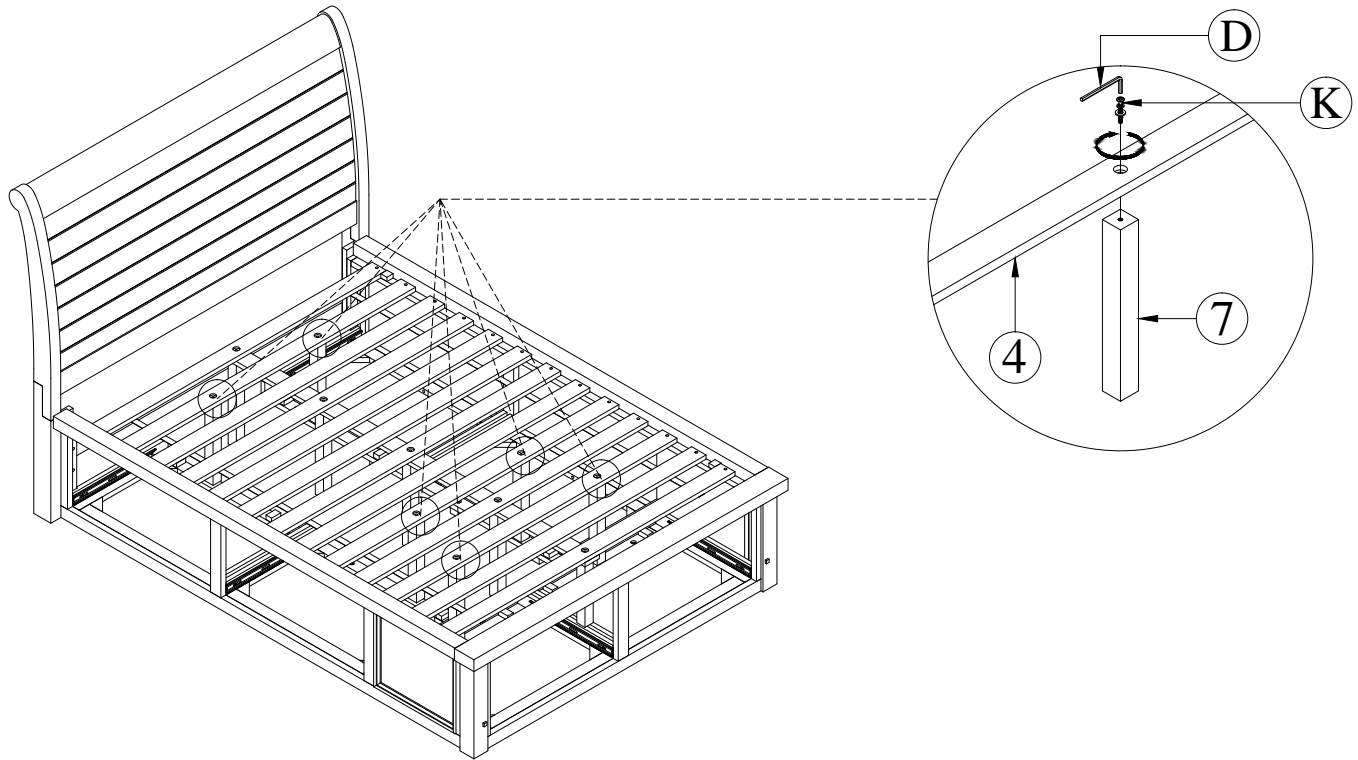

STEP 10: Use a screwdriver (not provided) to attach slat roll (4) to side rails (L/R) (3) by using screw (I).

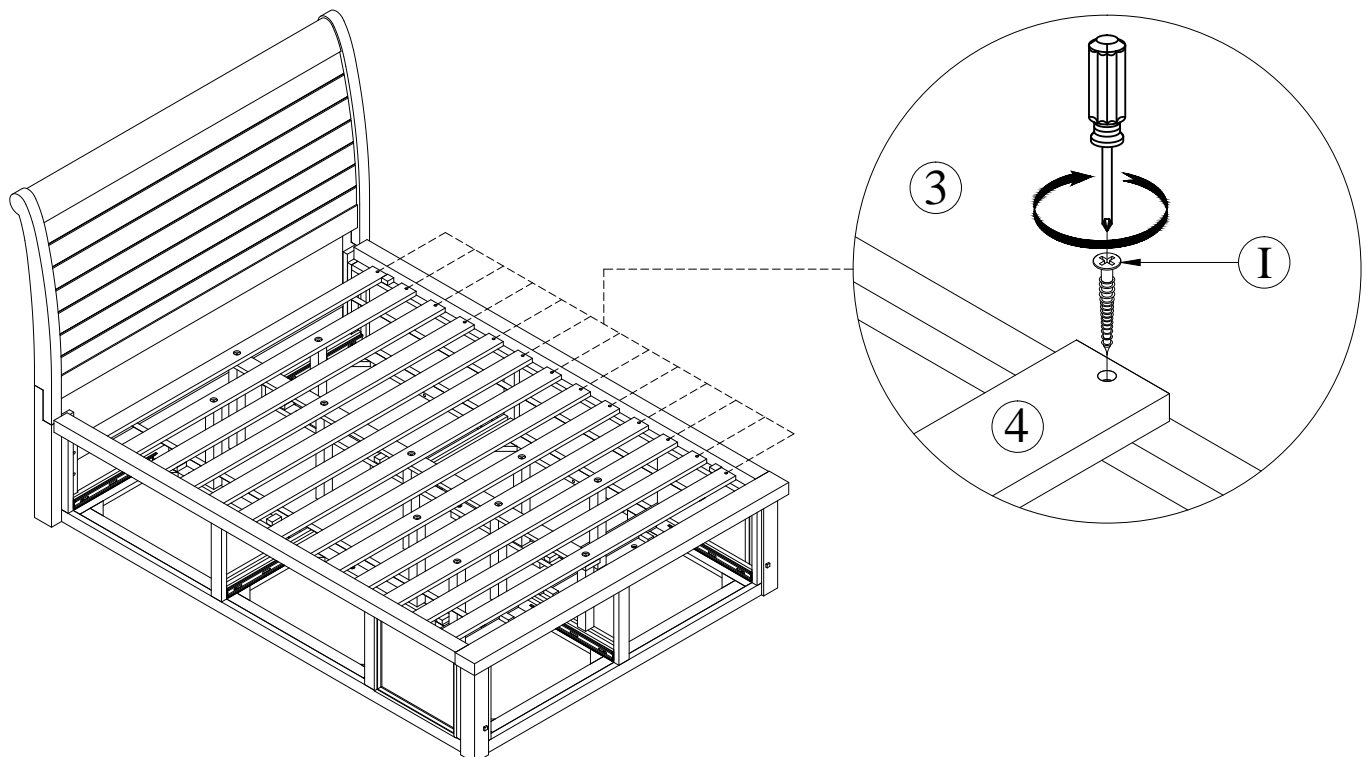

Thank you for purchasing this quality product. Be sure to check all packing material carefully for small parts that may have come loose inside the carton during shipment.

STEP 11: Put the drawers back in place.

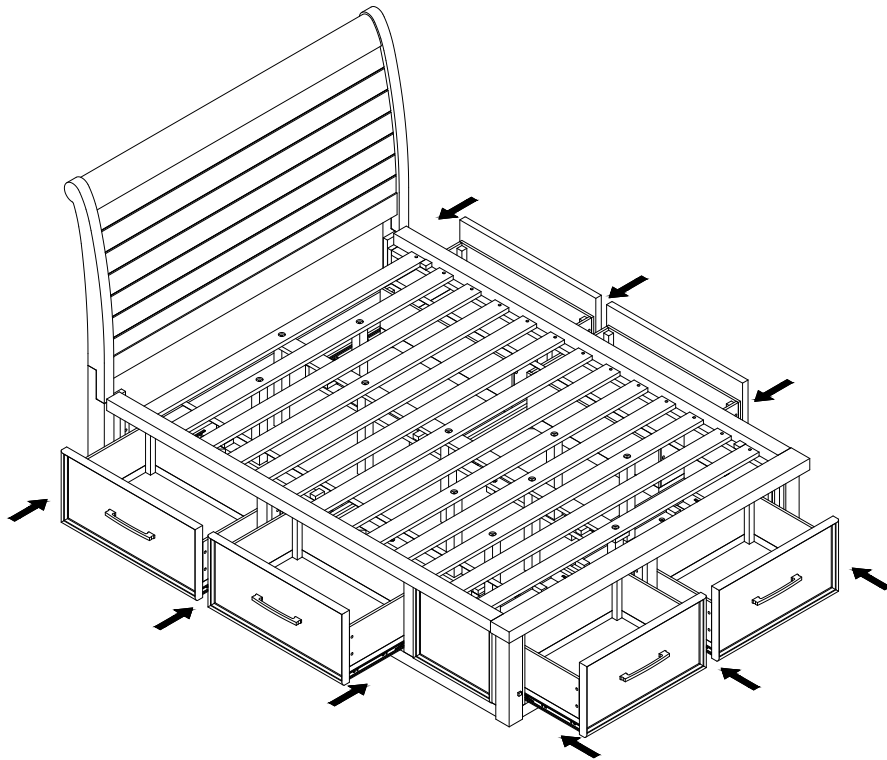

ASSEMBLY COMPLETE

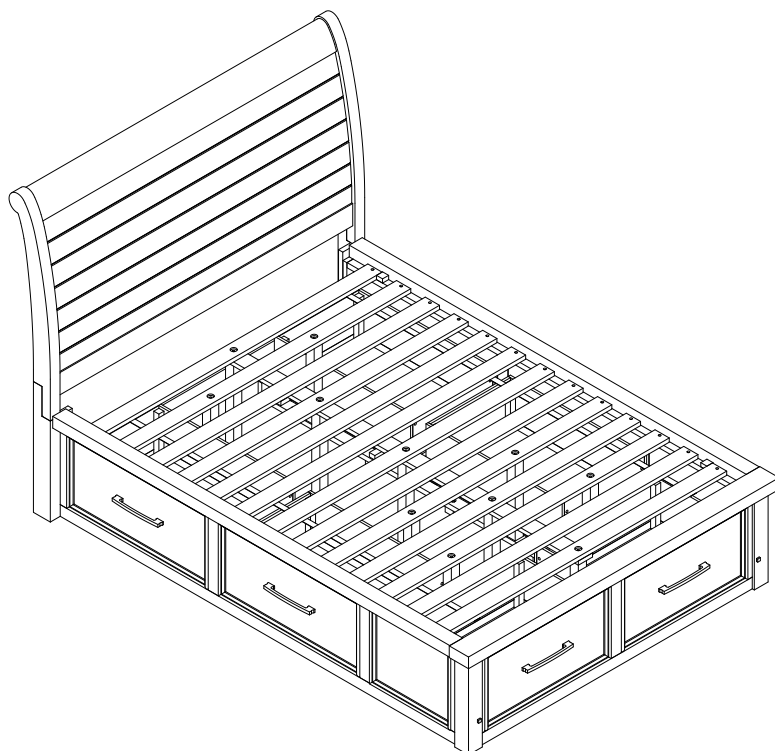



**WARNING: To avoid serious personal injury:**

- Carefully and strictly follow assembly instructions. Improper assembly of furniture can result in structural failure, instability of the product, or tip-over.
- Monitor and carefully control the assembly components. These include small parts and hardware that may present a choking hazard to small children. Bob's furniture should be assembled only by responsible adults and children should not be involved in the assembly process.
- Where provided, wall mounting hardware should always be used as prescribed in these instructions to anchor furniture to walls. Proper use of the wall mounting hardware can significantly reduce the potential for furniture tip-over and crushing injuries.