

Assembly Instructions

REV.1-PFT-8599-0125

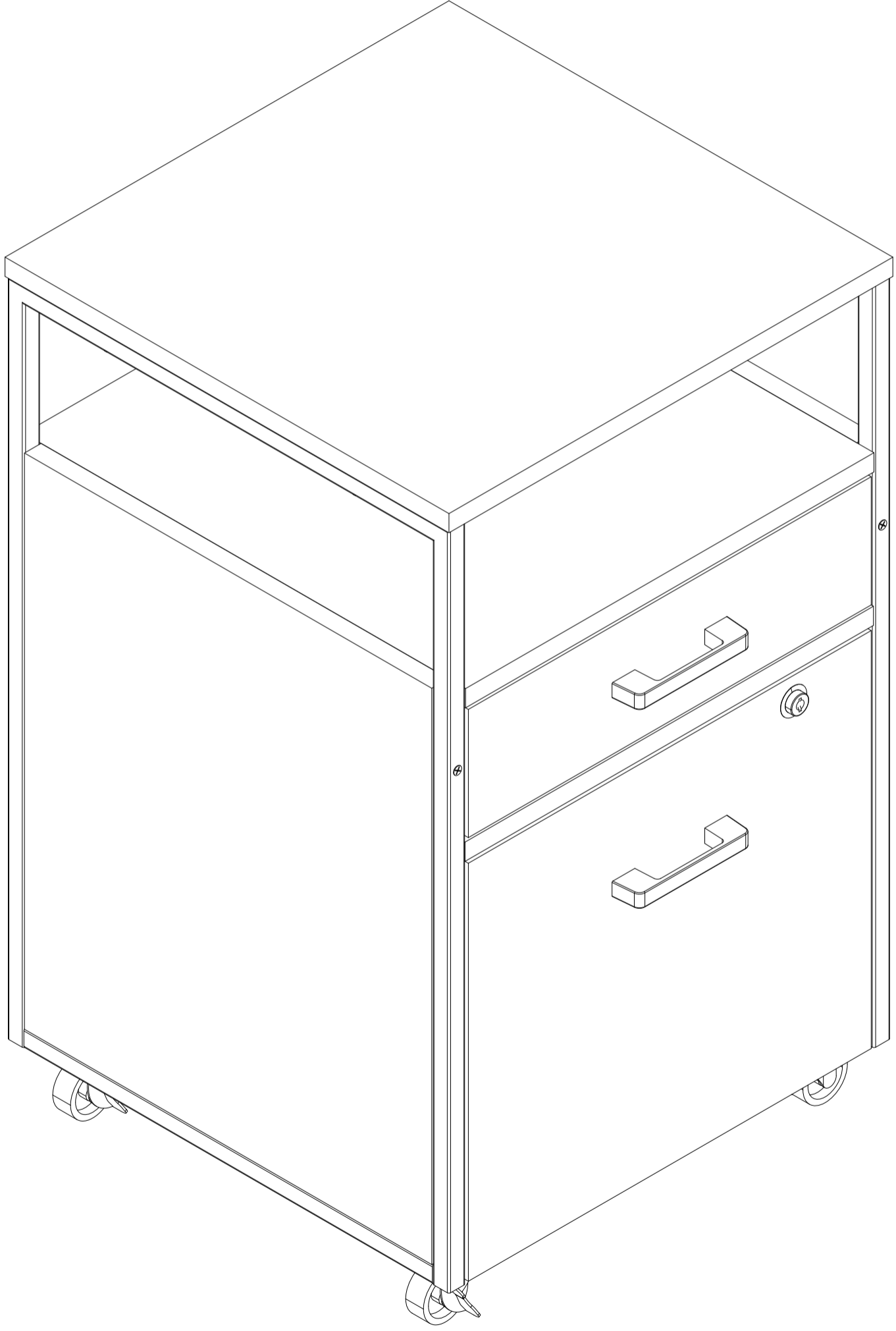

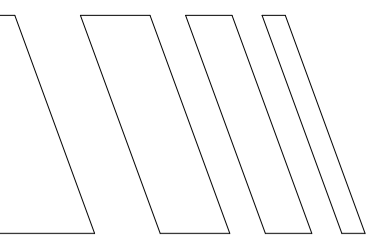

MAIN PARTS LIST

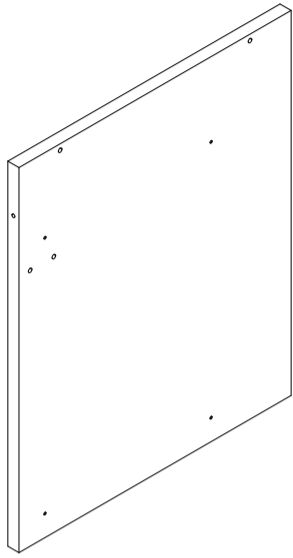
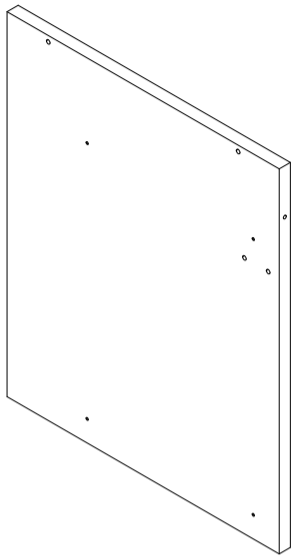
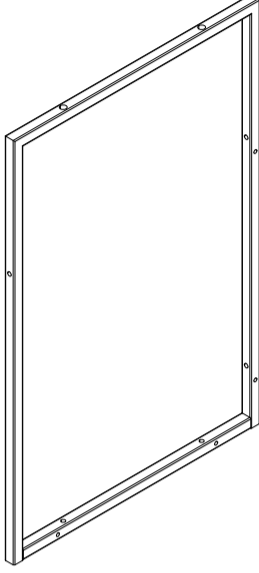
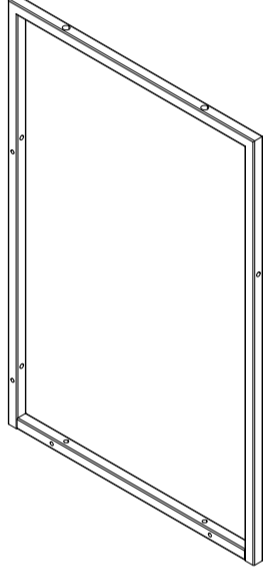
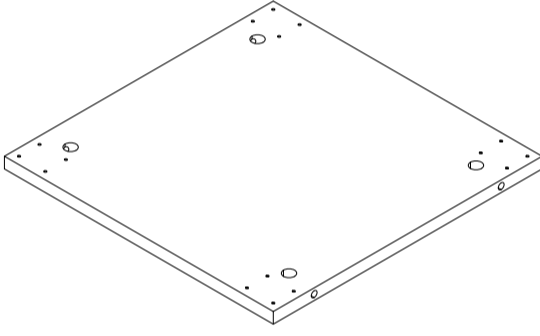
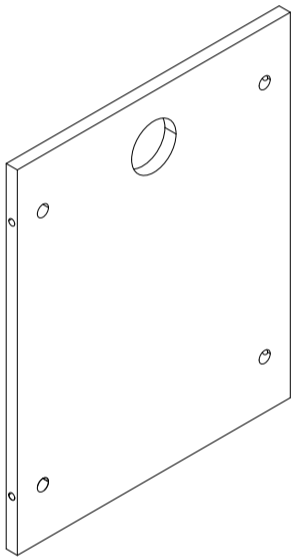
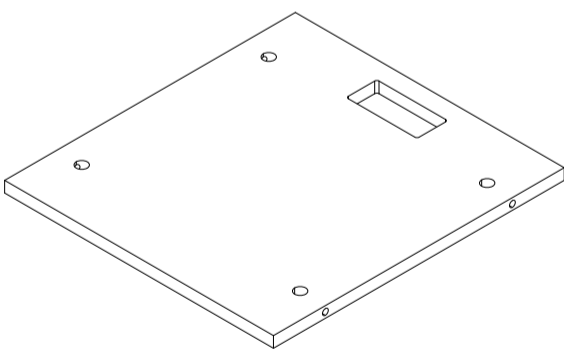
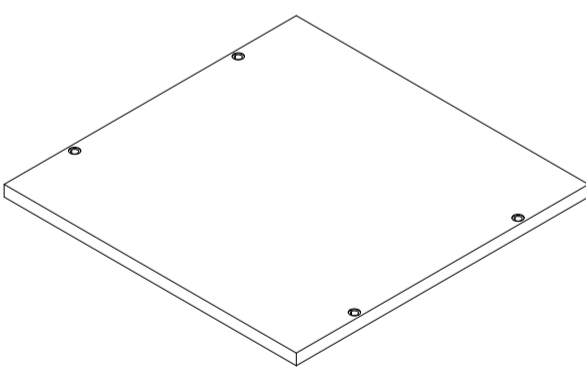
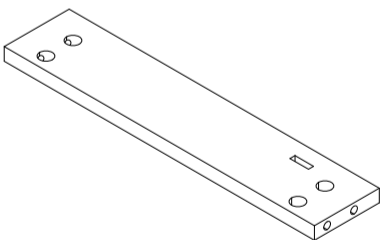
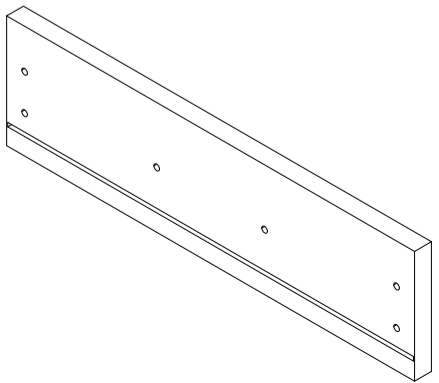
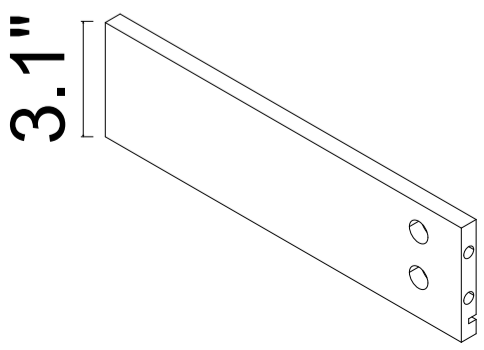
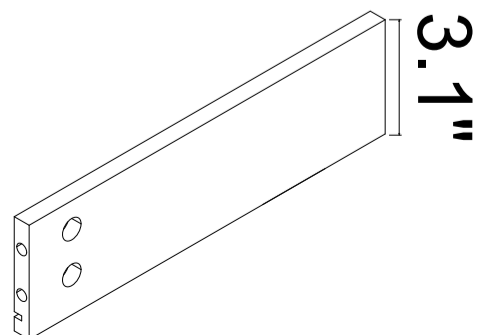
<p>1 Left panel</p> 	<p>2 Right panel</p> 	<p>3 Left frame</p> 
<p>4 Right frame</p> 	<p>5 Bottom panel</p> 	<p>6 Back panel</p> 
<p>7 Middle shelf</p> 	<p>8 Top panel</p> 	<p>9 Middle support</p> 
<p>10 Small drawer front</p> 	<p>11 Small drawer left</p> <p>3.1"</p> 	<p>12 Small drawer right</p> <p>3.1"</p> 

MAIN PARTS LIST

13 Small drawer back

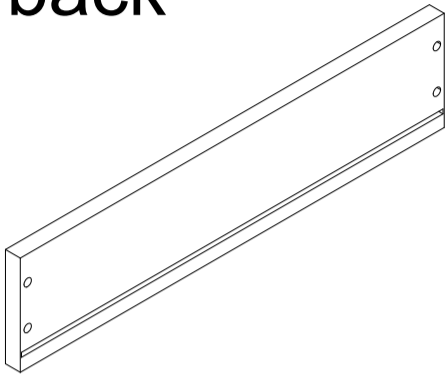

14 Small drawer bottom

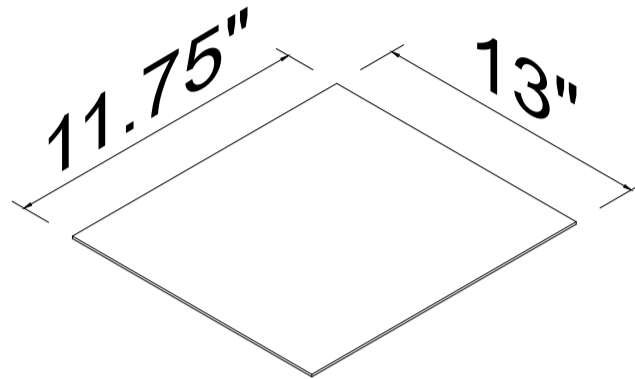

15 File drawer front

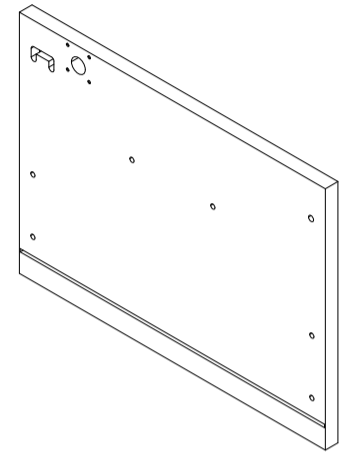

16 File drawer left

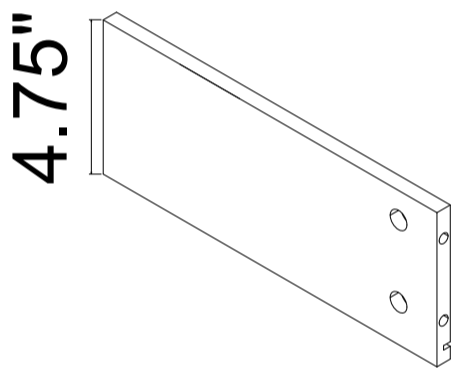

17 File drawer right

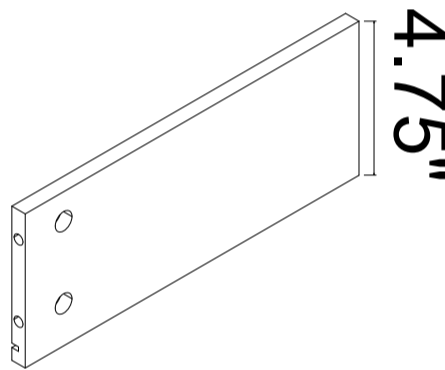

18 File drawer back

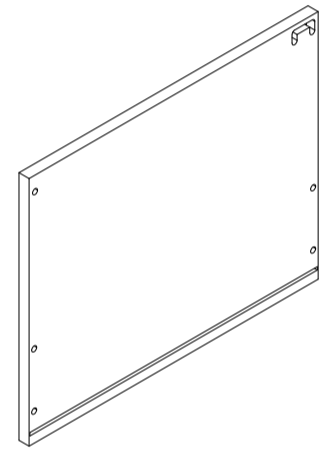

19 File drawer bottom

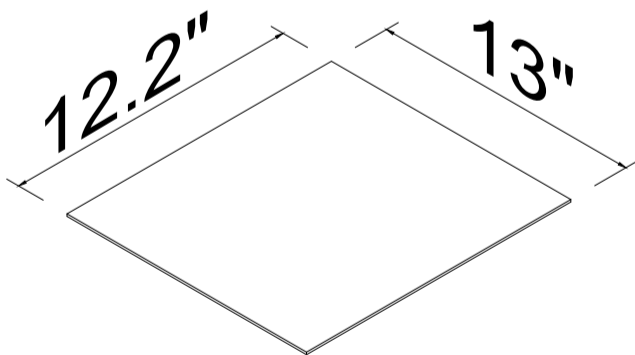

20 File rods

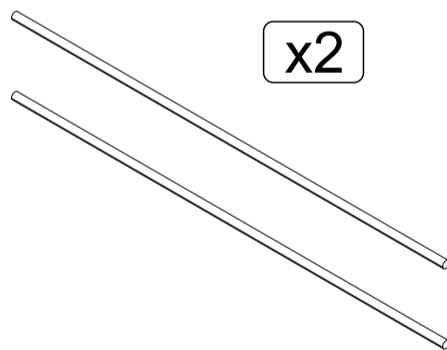

21 Drawer sliders, Set of 4 pcs.

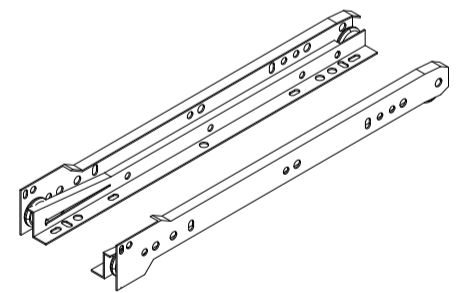

Each set for 1 drawer has 4 pieces:
 • Two "Flat" pieces
 • Two "L" shaped pieces.

22 Power and USB hub

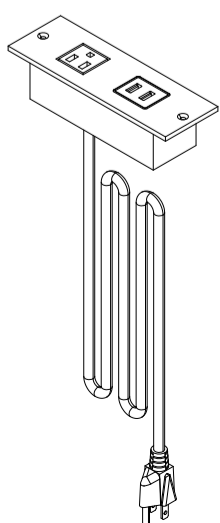

23 Casters

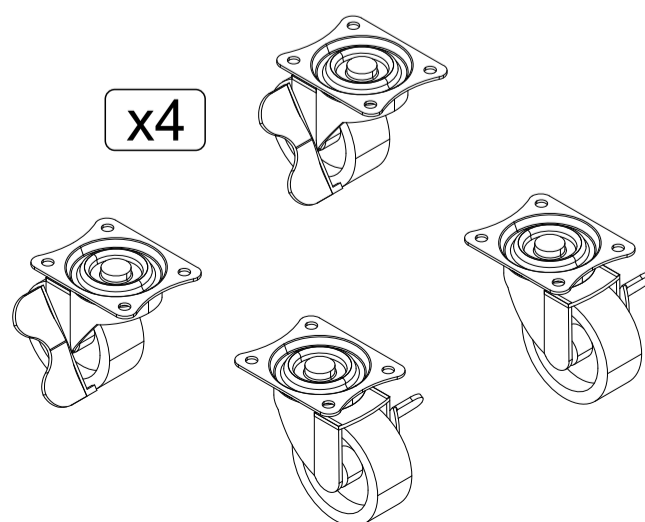



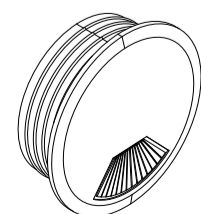

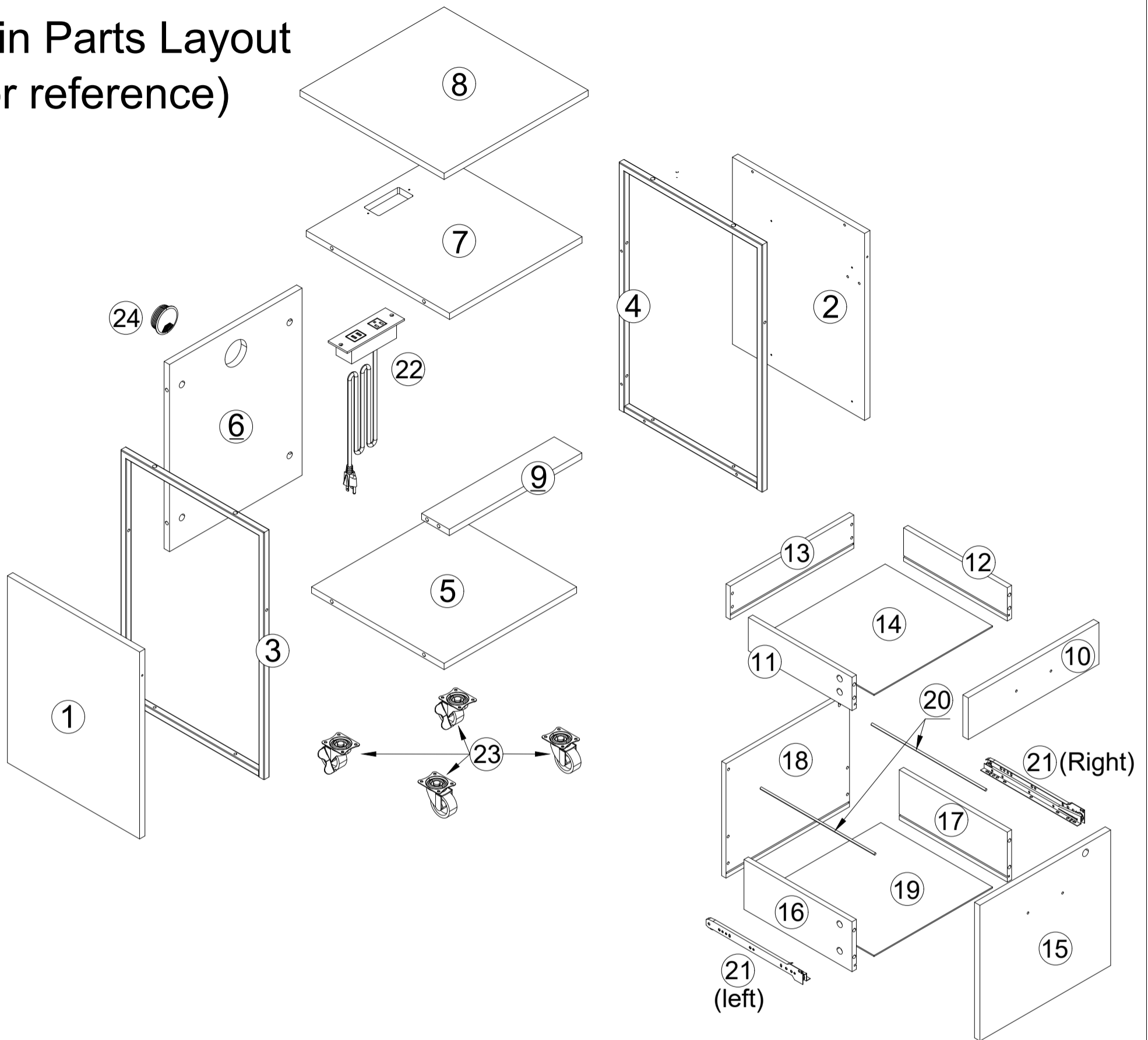

24 Grommet (Cable management)



Main Parts Layout (For reference)

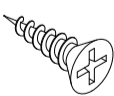
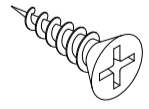
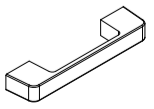
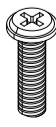
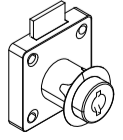
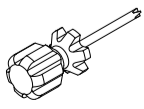

Hardware List

A M5x42	B M6x42	C Ø15x10	D M6x25	E M5x40	F M3.5x14	G M3.5x18
						
16 PCS	8 PCS	24 PCS	4 PCS	18 PCS	34 PCS	4 PCS
H	I M4x18	J		3#	4#	
						
2 PCS	4 PCS	1 PCS	1 PCS	1 PCS	1 PCS	

ASSEMBLY STEPS

1 Assemble #1 to #3 with screws E.

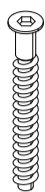

E M5x40

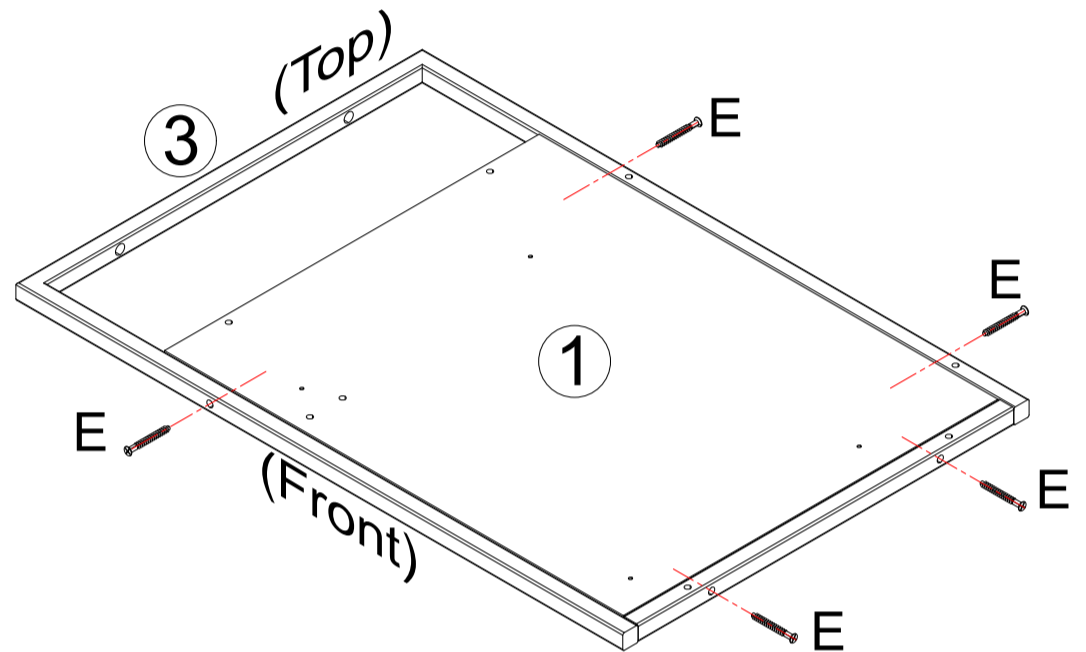
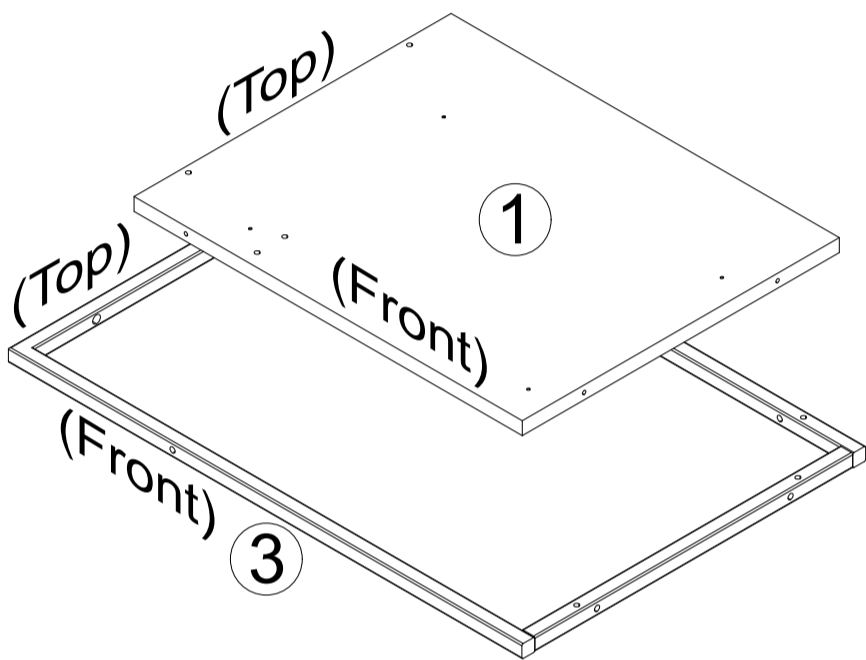

5 PCS



2 FIRST: Attach only the Left "Flat" sliders #21 to #1 with screws F.

A M5x42	B M6x42	F M3.5x14
		
4 PCS	4 PCS	4 PCS

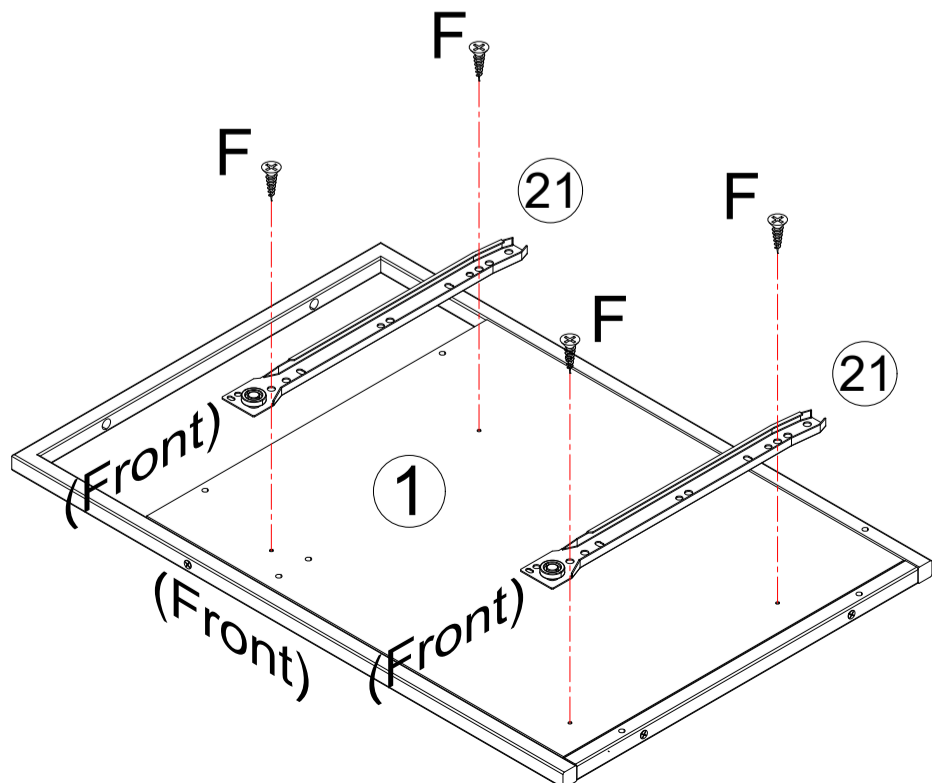
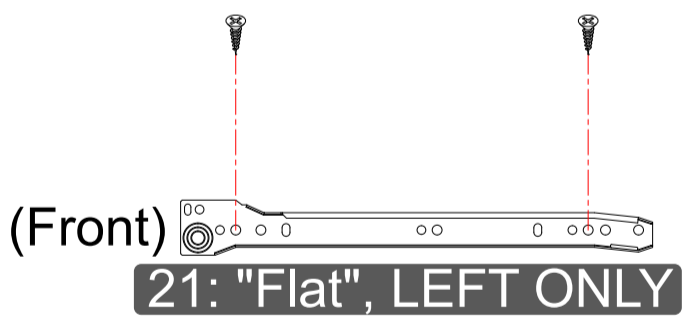

A on the panel,
B on the frame

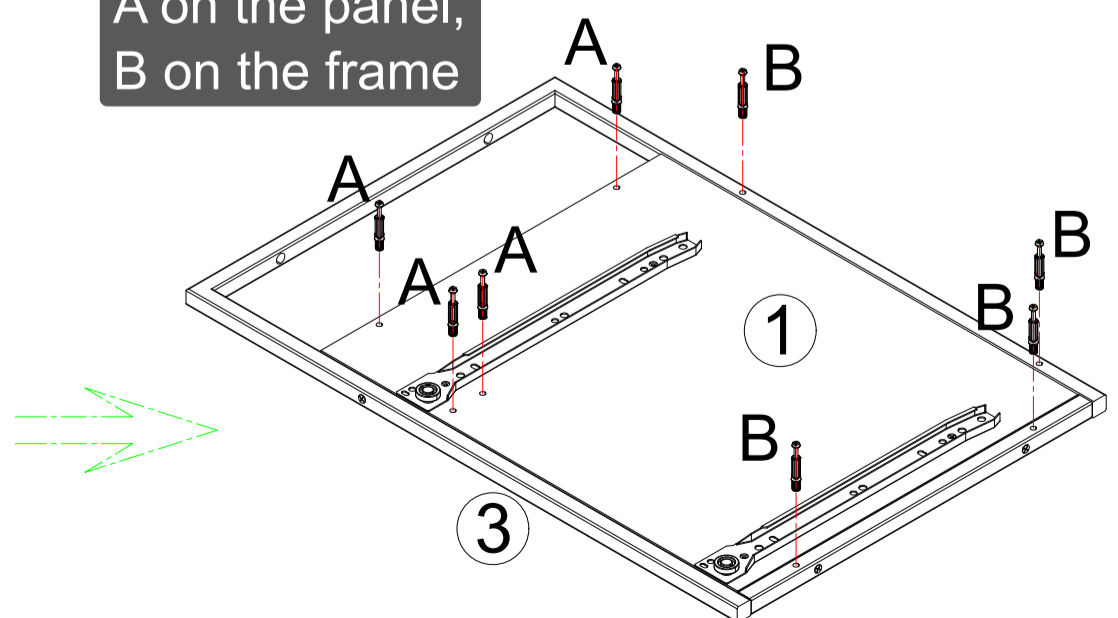

THEN: Attach bolts A to #1, and bolts B to #3 in the indicated holes.

3

Assemble #2 to #4 with screws E.

E M5x40



5 PCS

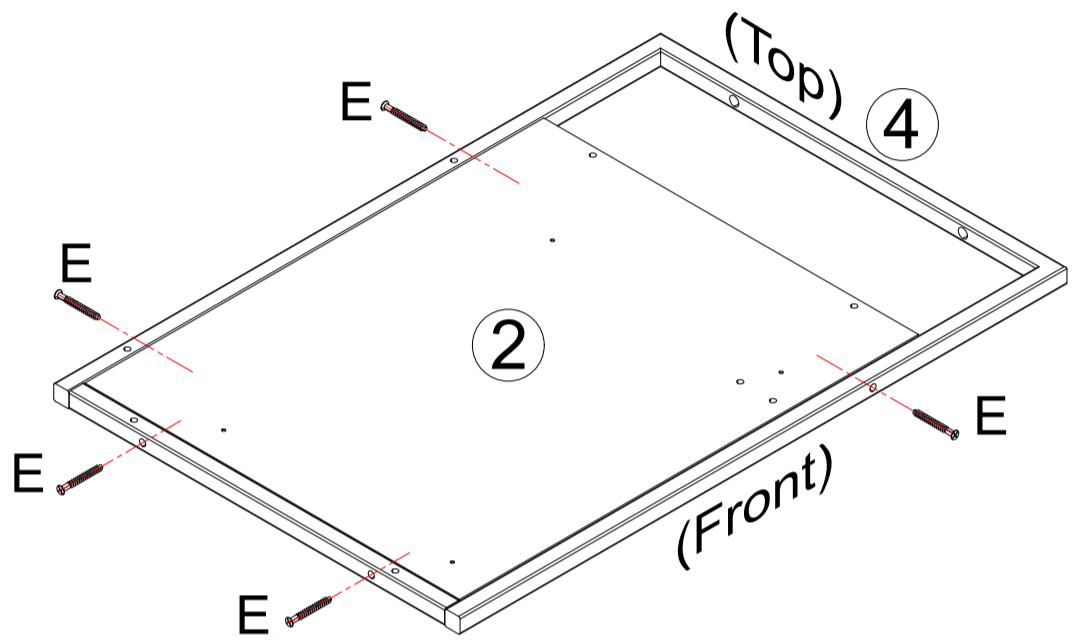
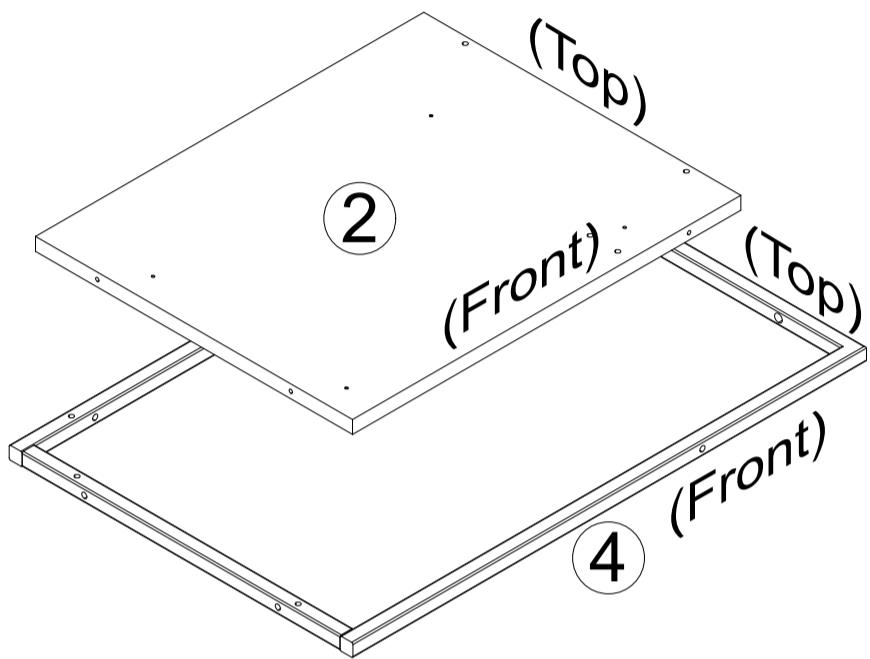

4

FIRST: Attach only the Right "Flat" sliders #21 to #1 with screws F.

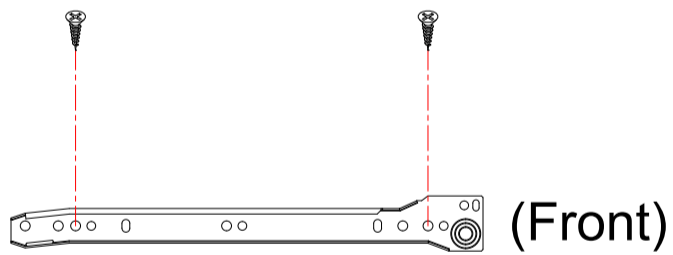

21: "Flat", RIGHT ONLY

A M5x42	B M6x42	F M3.5x14
4 PCS	4 PCS	4 PCS

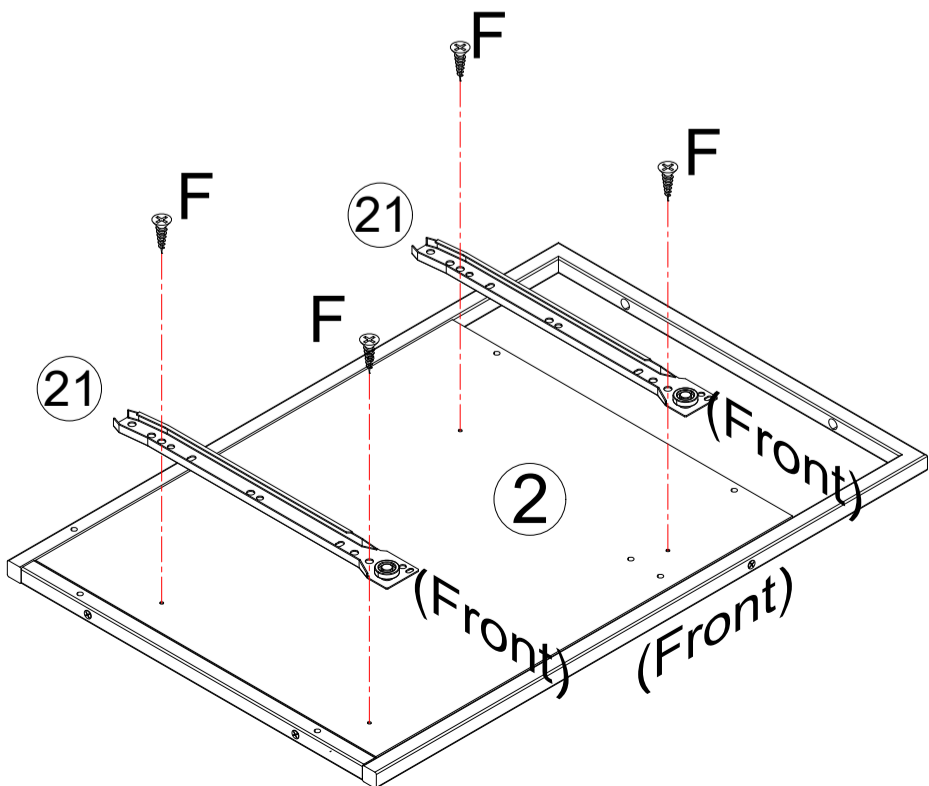

**A on the panel,
B on the frame**

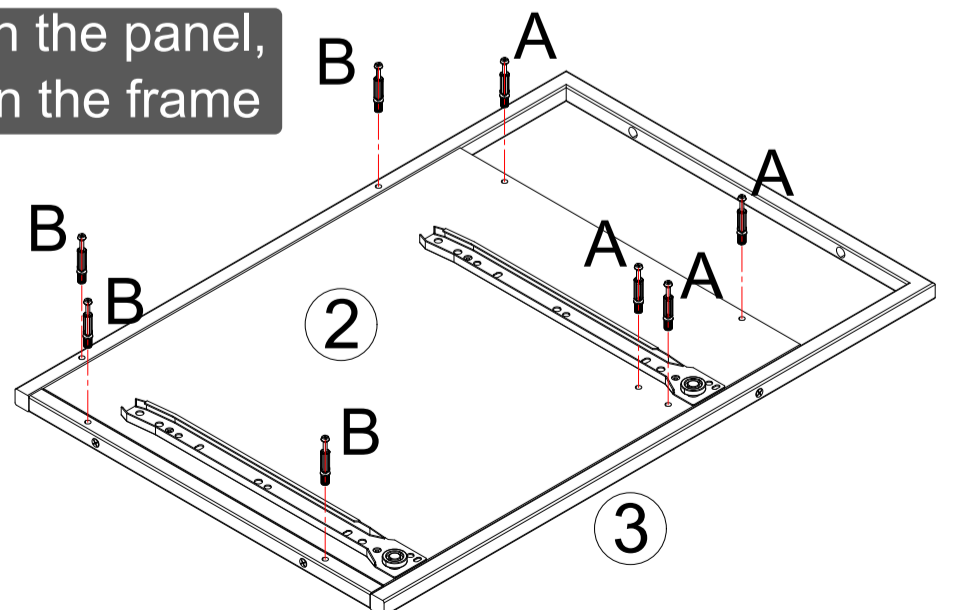

THEN: Attach bolts A to #1, and bolts B to #3 in the indicated holes.

5

FIRST: Join #7 to #1.

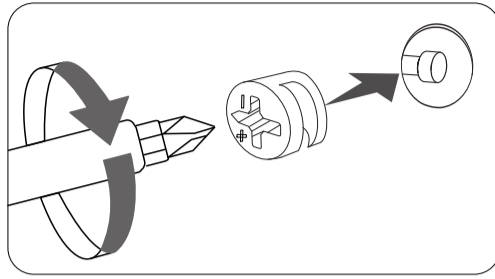

C Ø15x10



2 PCS

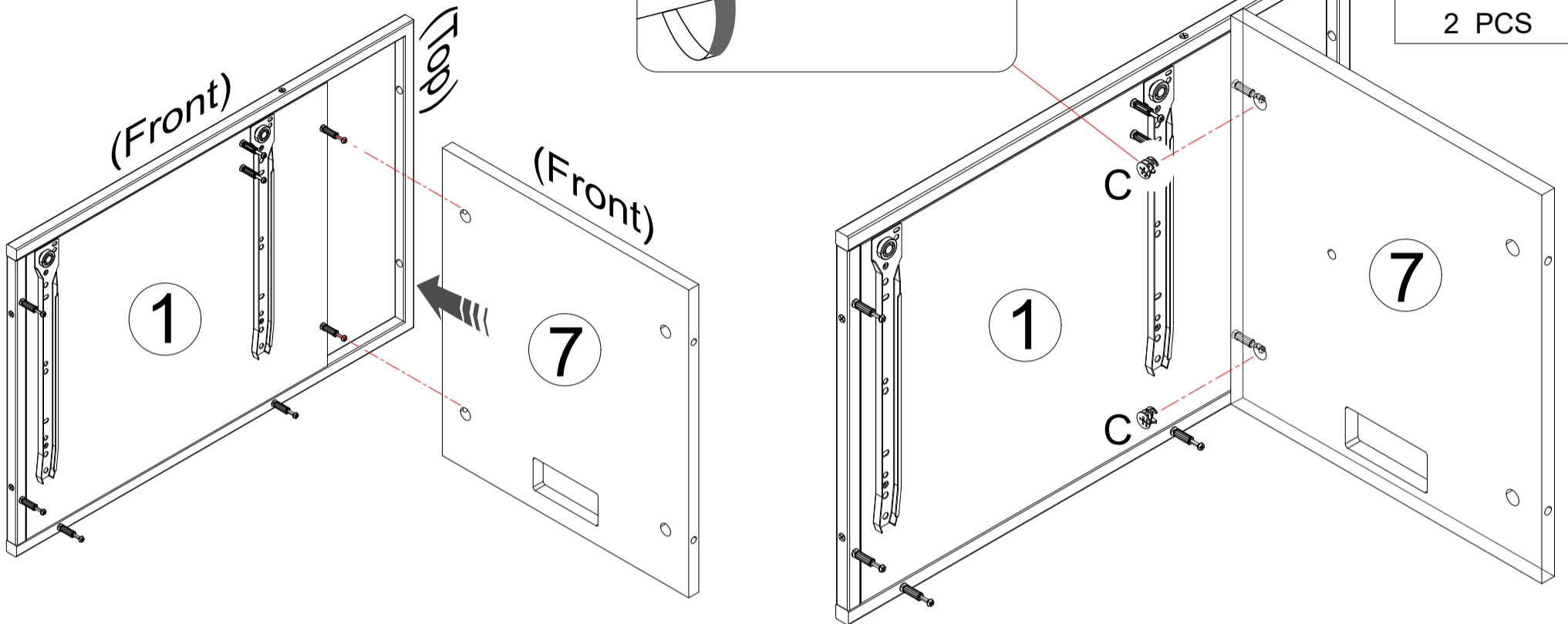

THEN: insert the cam locks C into #7, and turn them to secure and lock the pieces together.

6

Assemble #6 to #3 by inserting and turning cam locks C into #6.

C Ø15x10



2 PCS

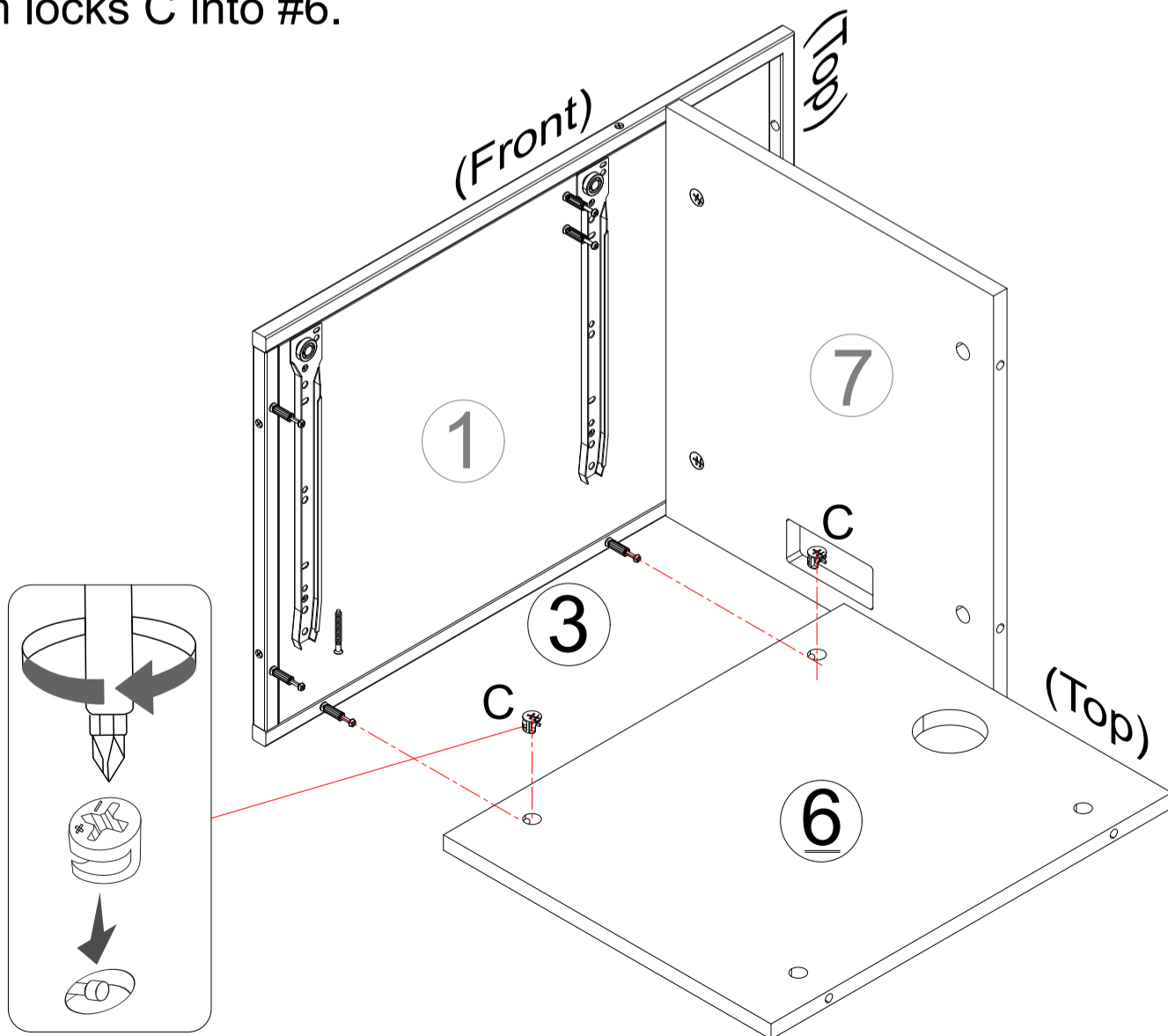

7

Assemble #5 to #3 with cam locks C as done before.

C Ø15x10



2 PCS

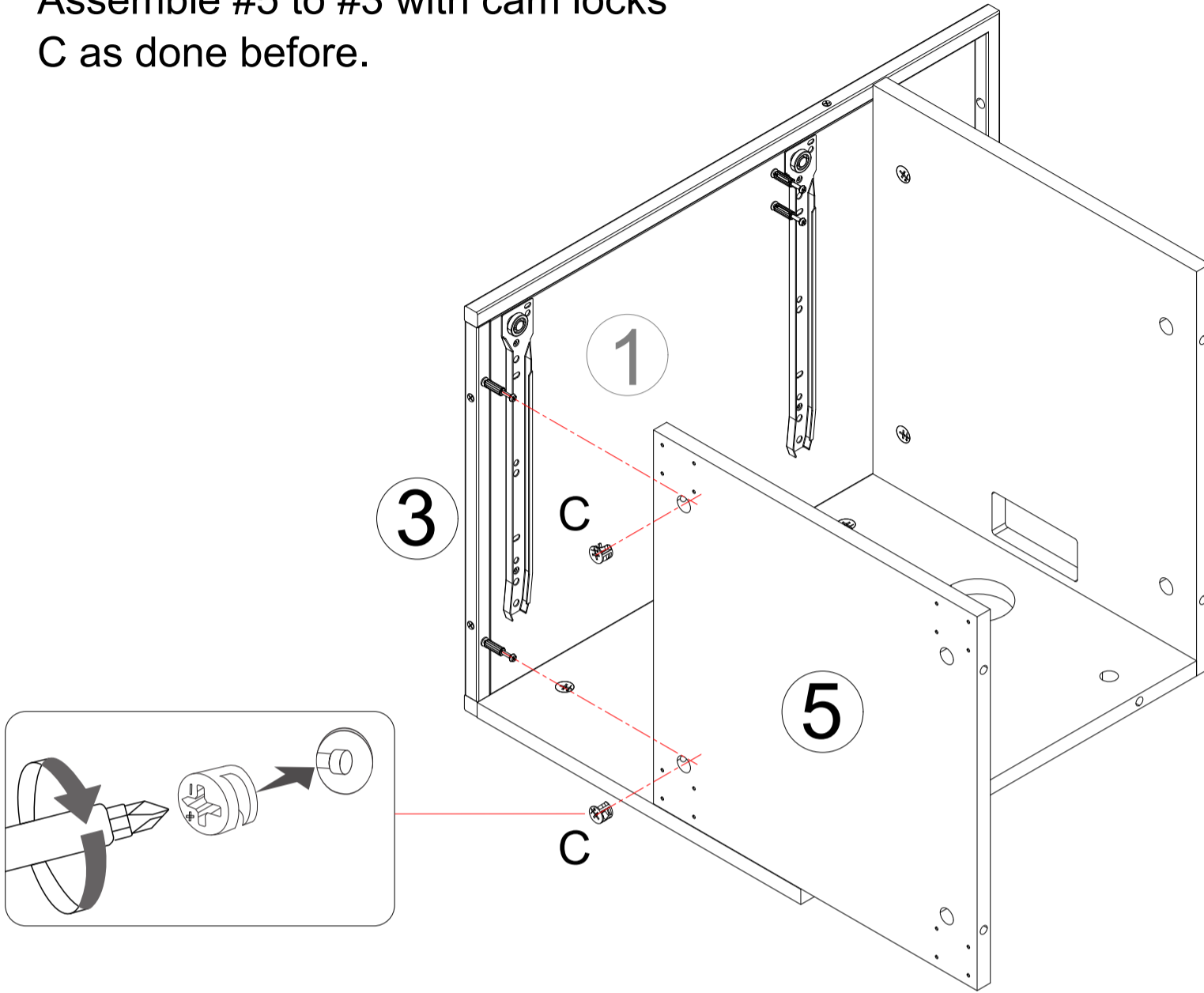

8

Assemble #9 to #1 with cam locks C.

C Ø15x10



2 PCS

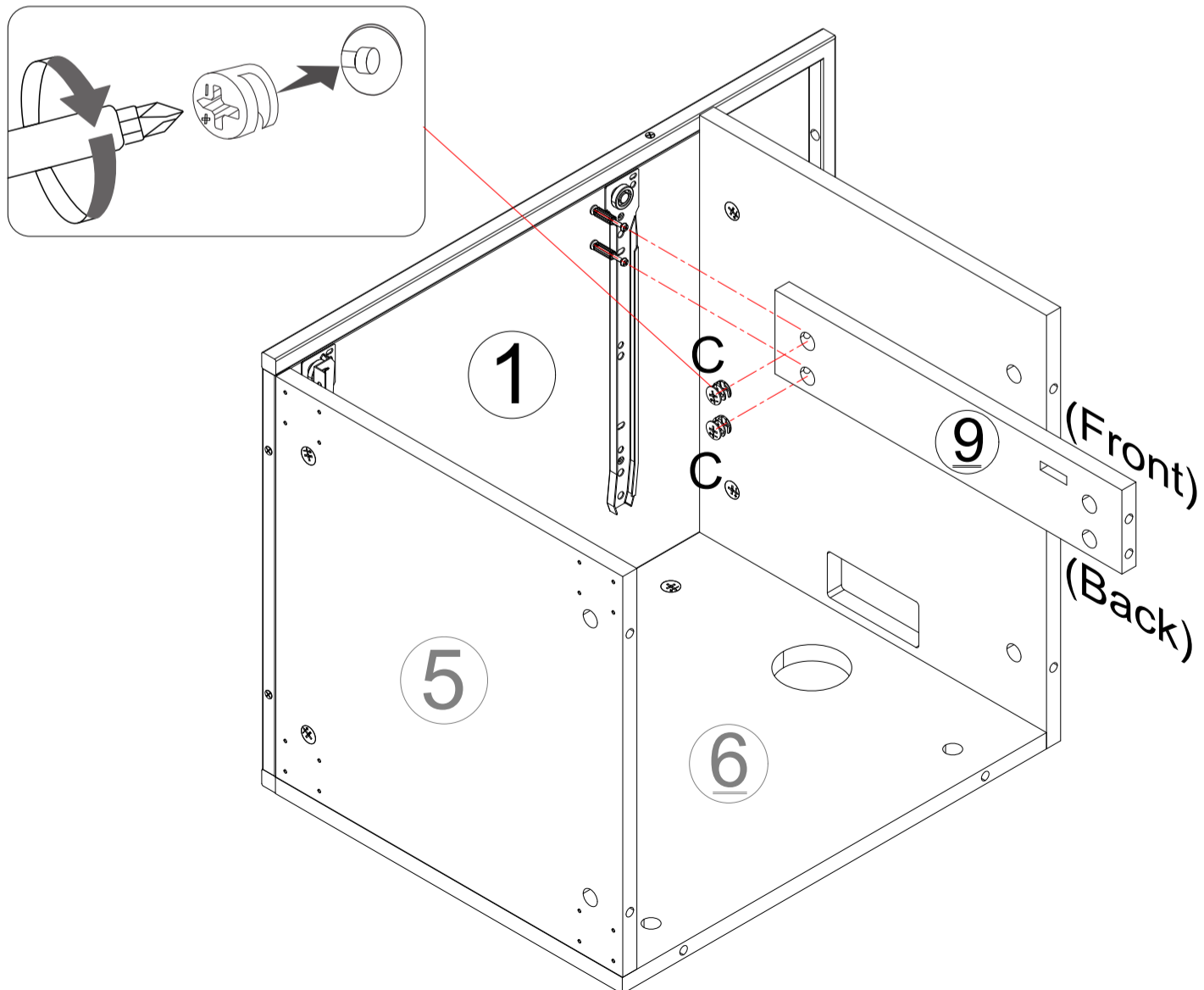

9

Assemble #2 and #4 to #5, #6, #7 and #9 with cam locks C as done before.

C Ø15x10



8 PCS

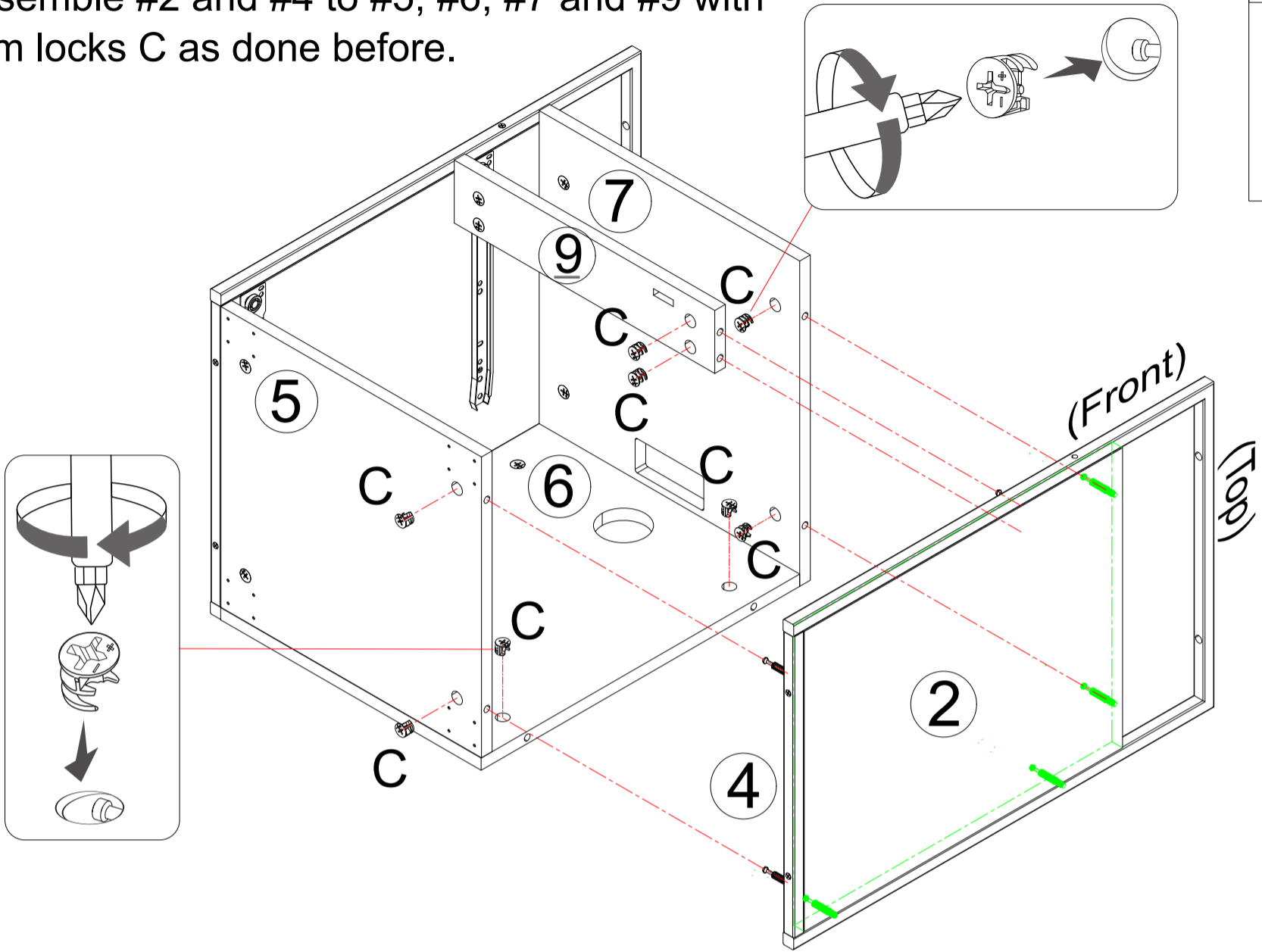

10

Attach the casters #23 to #5 with screws F.

F M3.5x14



16 PCS

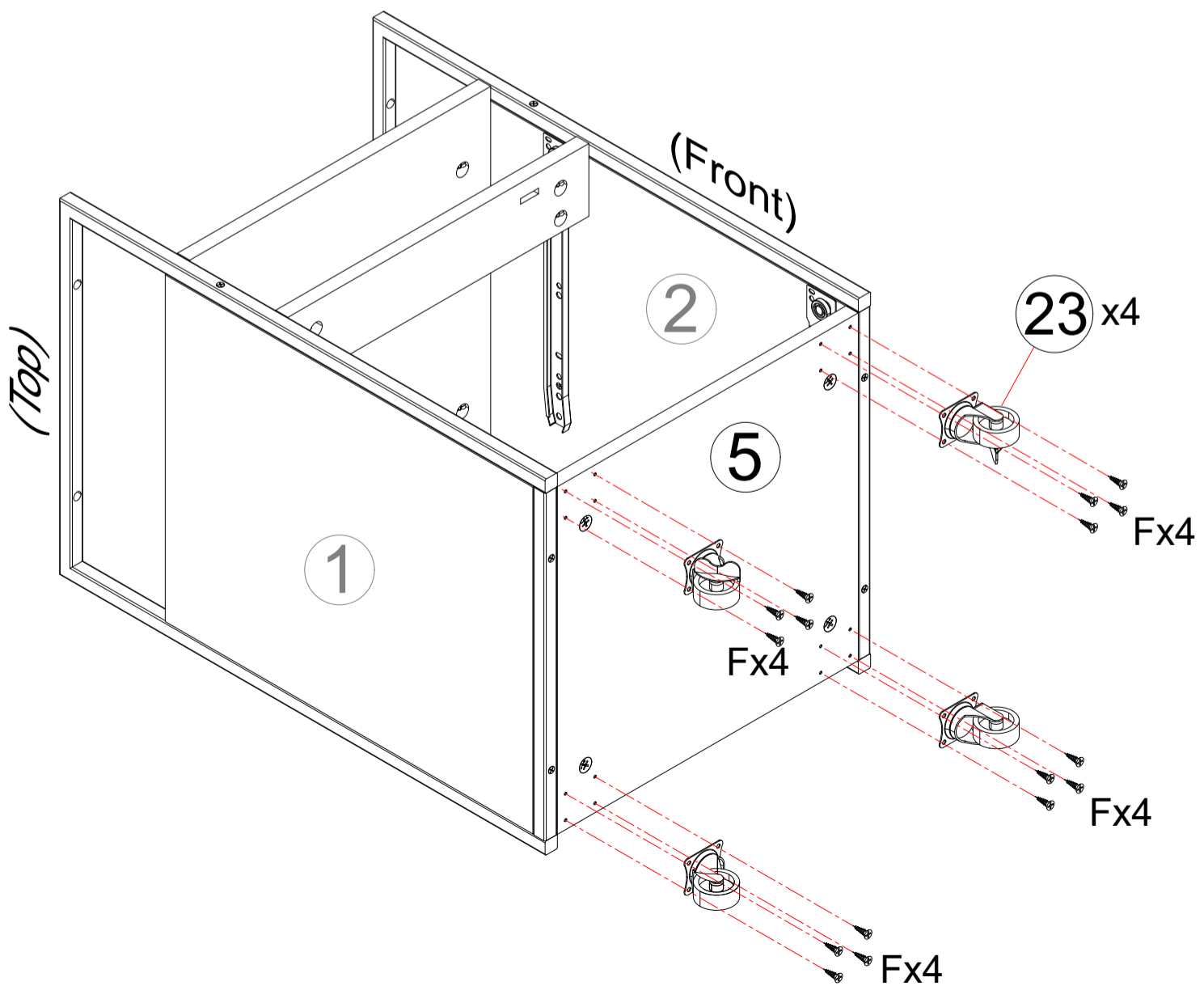

11

Assemble #22 to #7 with screws F.

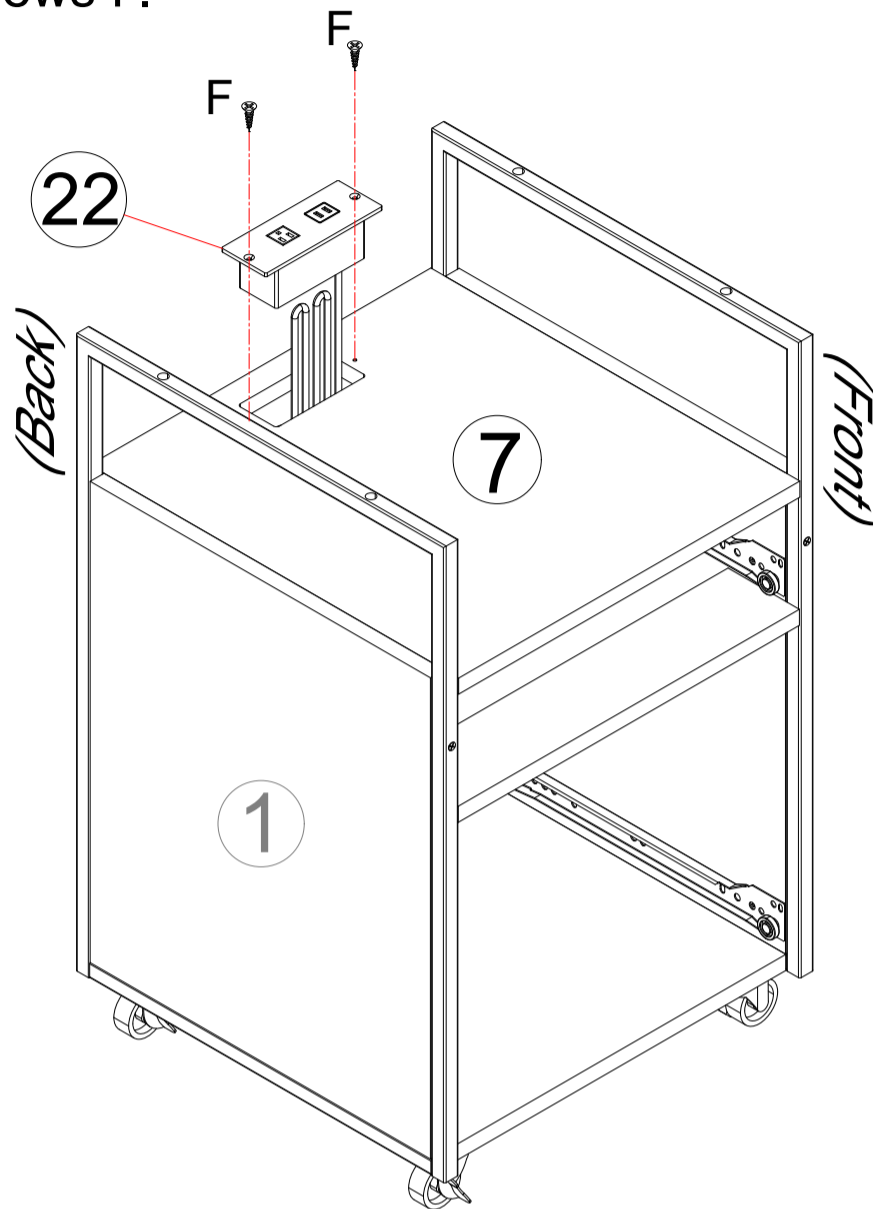

F M3.5x14

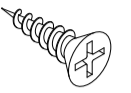

2 PCS

12

FIRST: Assemble #8 to #3 and #4 with screws D.

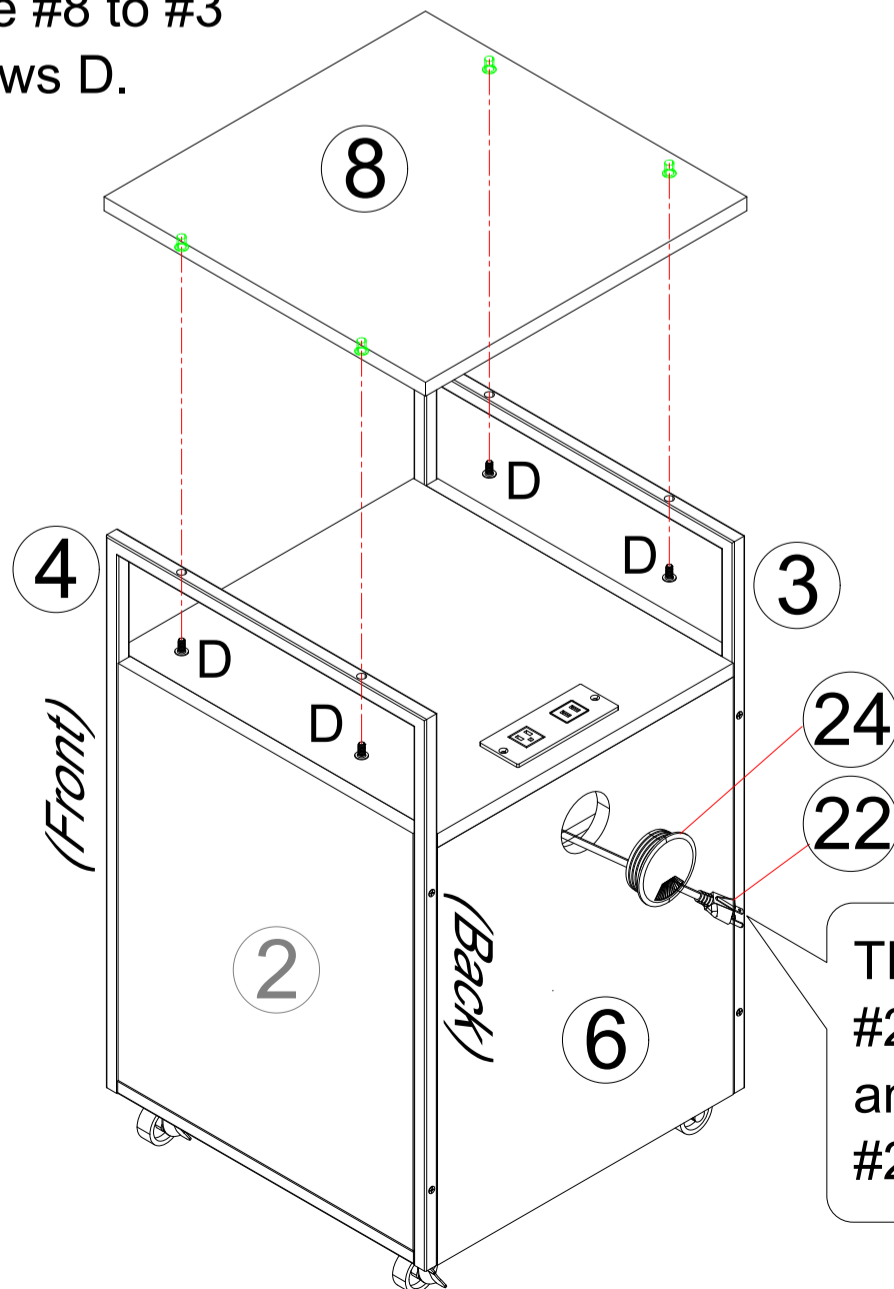

D M6x25



4 PCS

THEN: Pass the cable from #22 through the hole of #6 and the grommet #24, and fit #24 into the hole.

13

FIRST: Assemble #13 to #11 and #12 with screws E.

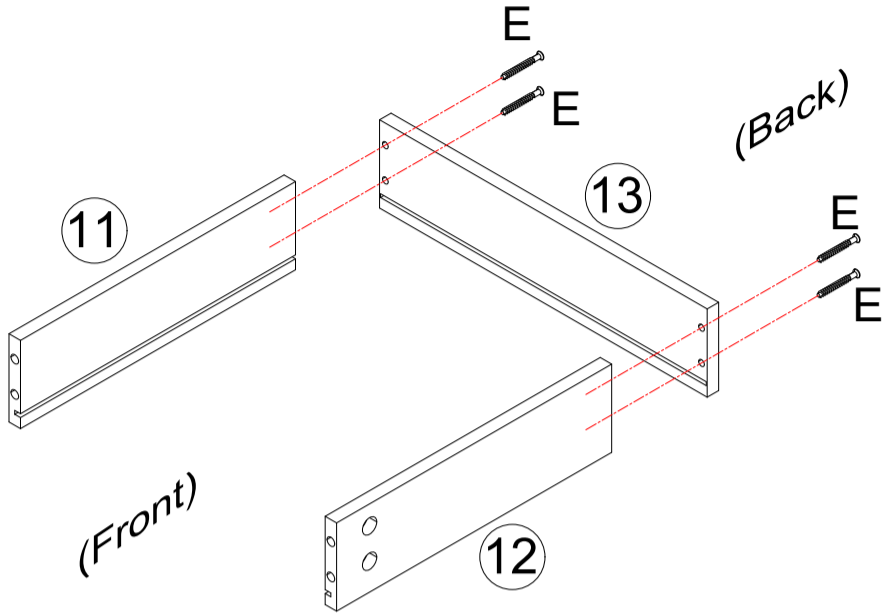

THEN: Slide #14 through #11 and #12 and into #13.

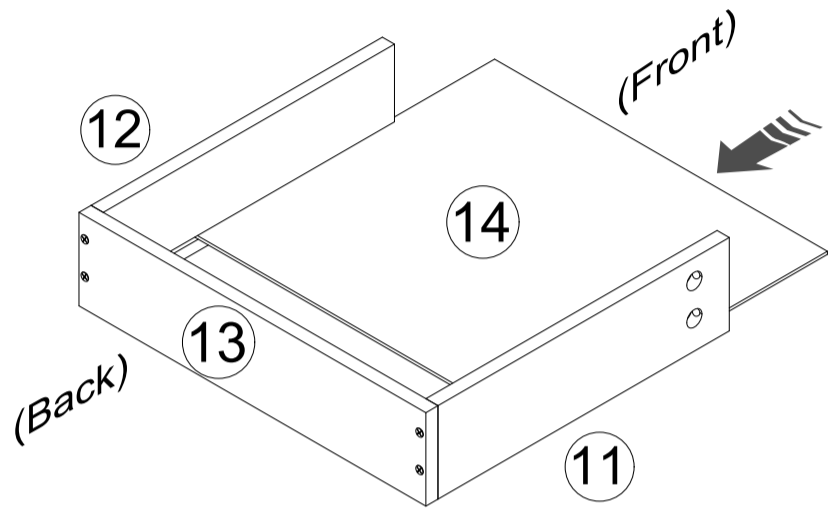

E M5x40

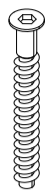



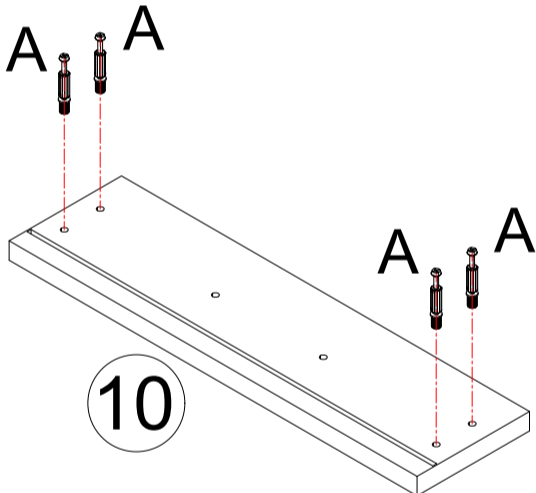

4 PCS

14

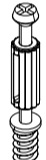
FIRST: Attach the bolts A into the indicated holes on #10.

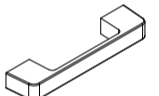

A M5x42	C Ø15x10	H	I M4x18
			
4 PCS	4 PCS	1 PCS	2 PCS

THEN: Assemble #10 to #11 and #12 with cam locks C.

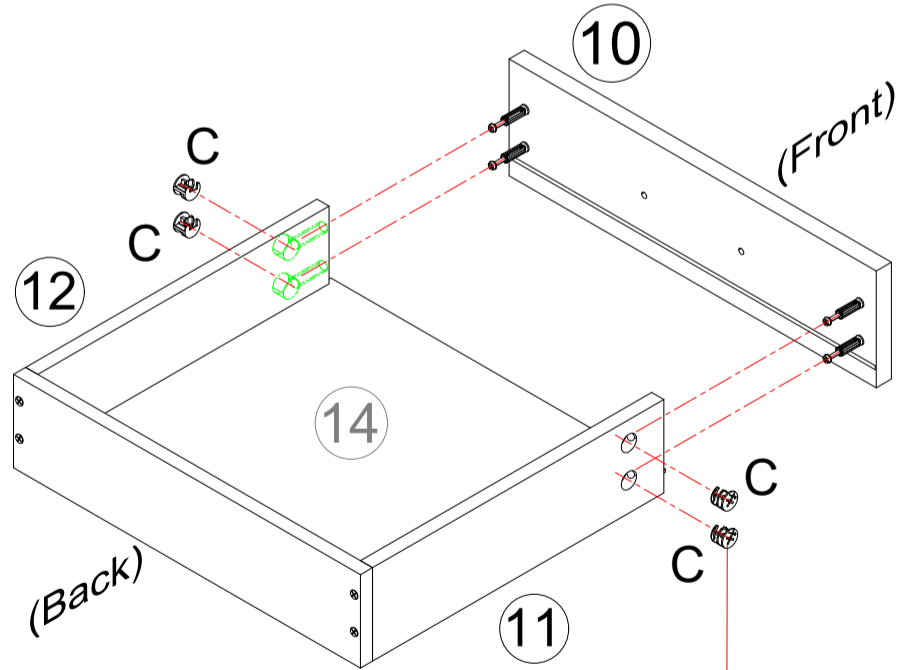

LAST: Attach the handle H to #10 with screws I.

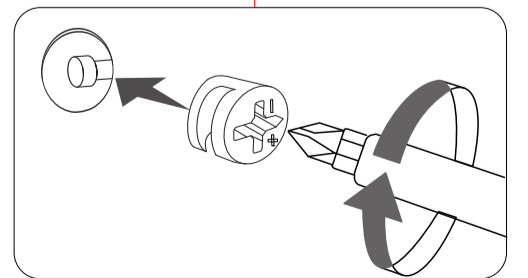
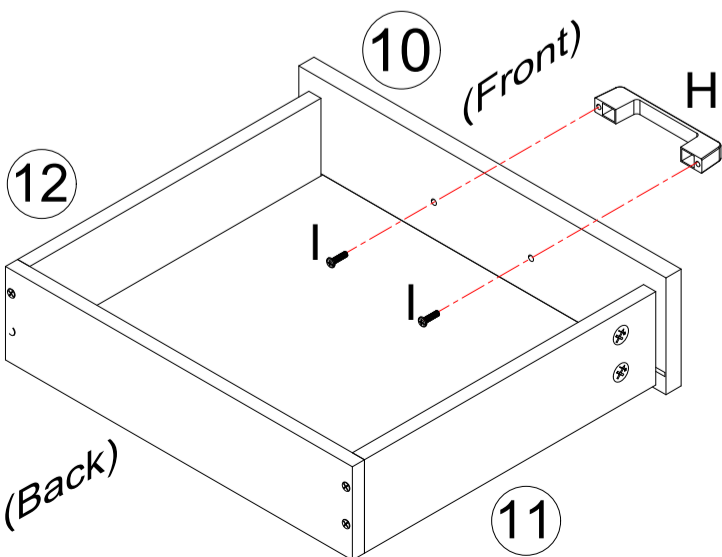

15

Attach the "L" shaped sliders #21 to the bottom of the drawer with screws F, making sure the wheels go towards the back of the drawer.

F M3.5x14

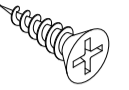

4 PCS

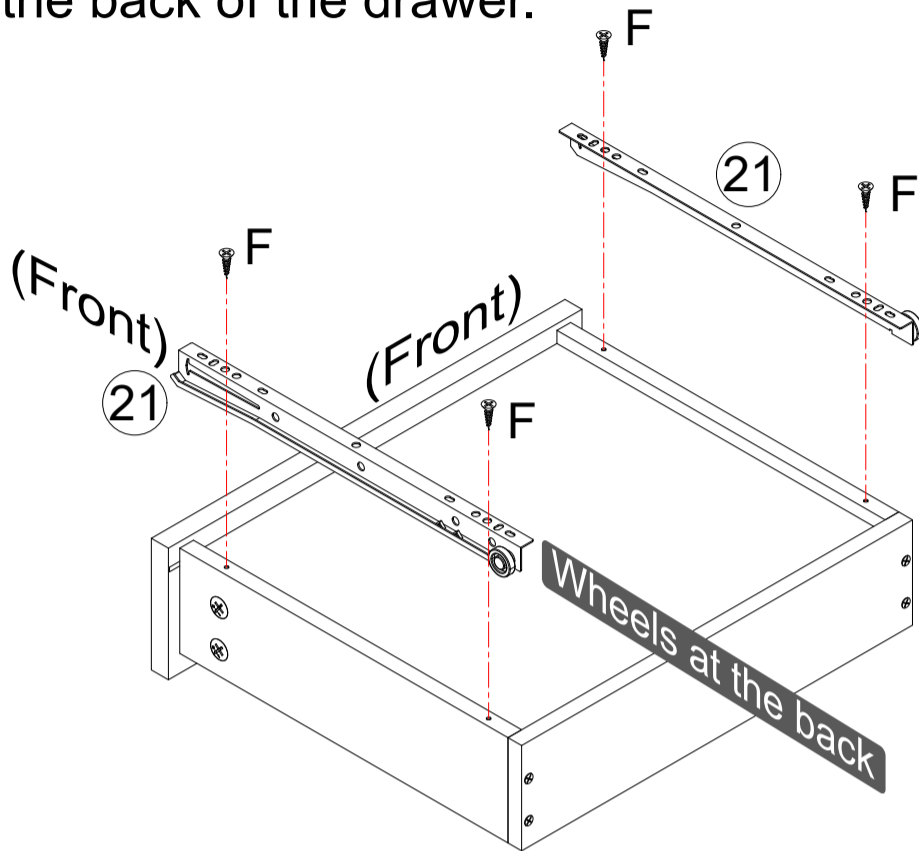

When finished, the sliders on the drawer will look like this:

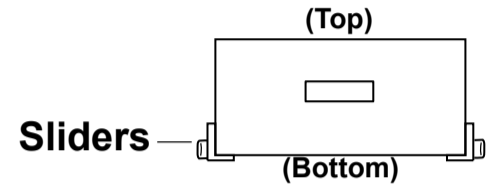

A wrong installation as below will raise the drawers 1" and won't fit!



16

FIRST: Attach the bolts A into the indicated holes on #15.

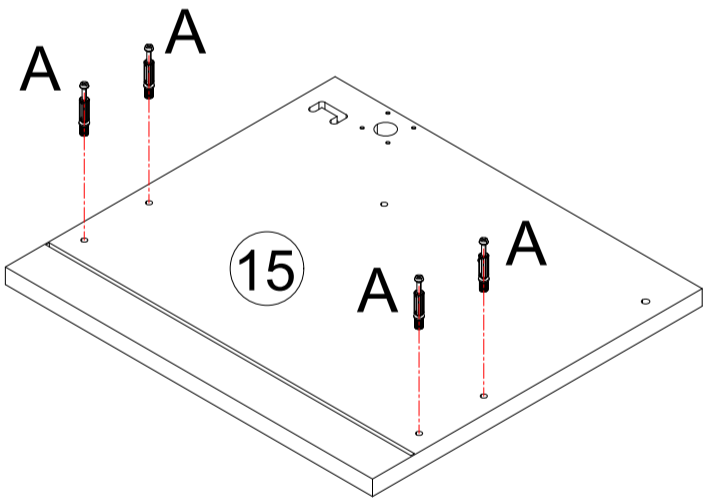

A M5x42



4 PCS

C Ø15x10



4 PCS

THEN: Assemble #16 and #17 to #15 with cam locks C.

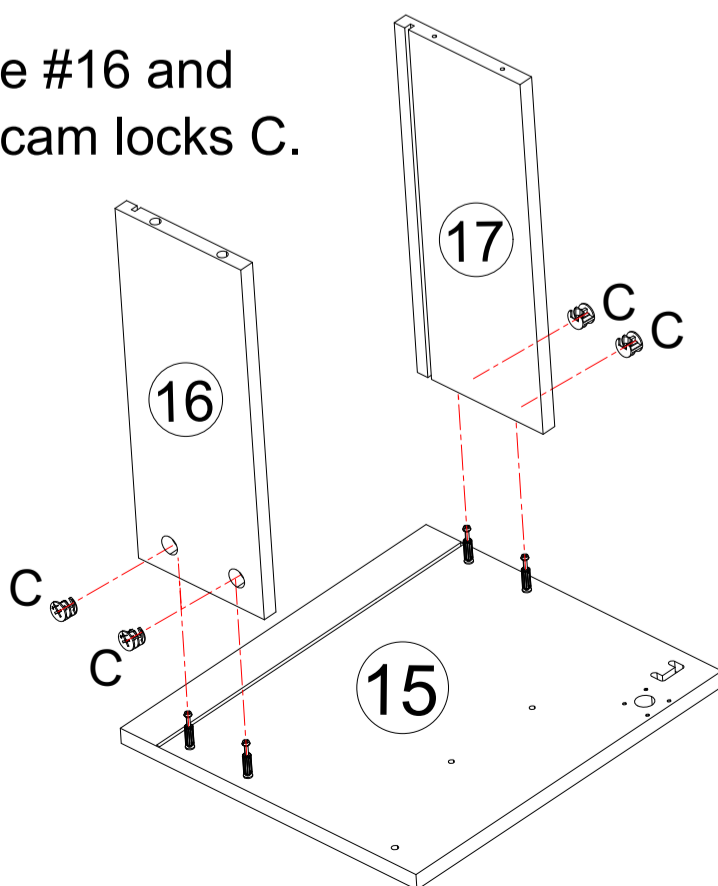

LAST: Slide #19 through #16 and #17 and into #15.

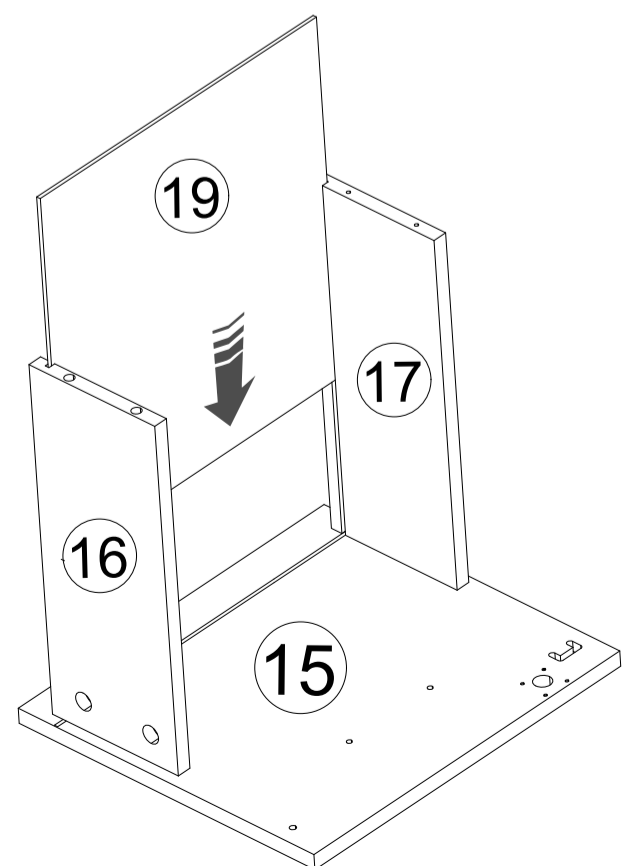

17

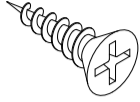
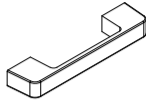
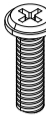
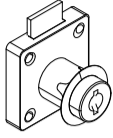
E M5x40	G M3.5x18	H	I M4x18	J
				
4 PCS	4 PCS	1 PCS	2 PCS	1 PCS

FIRST: Assemble #18 to #16 and #17 with screws E, and with the rods #20 in between #15 and #18.

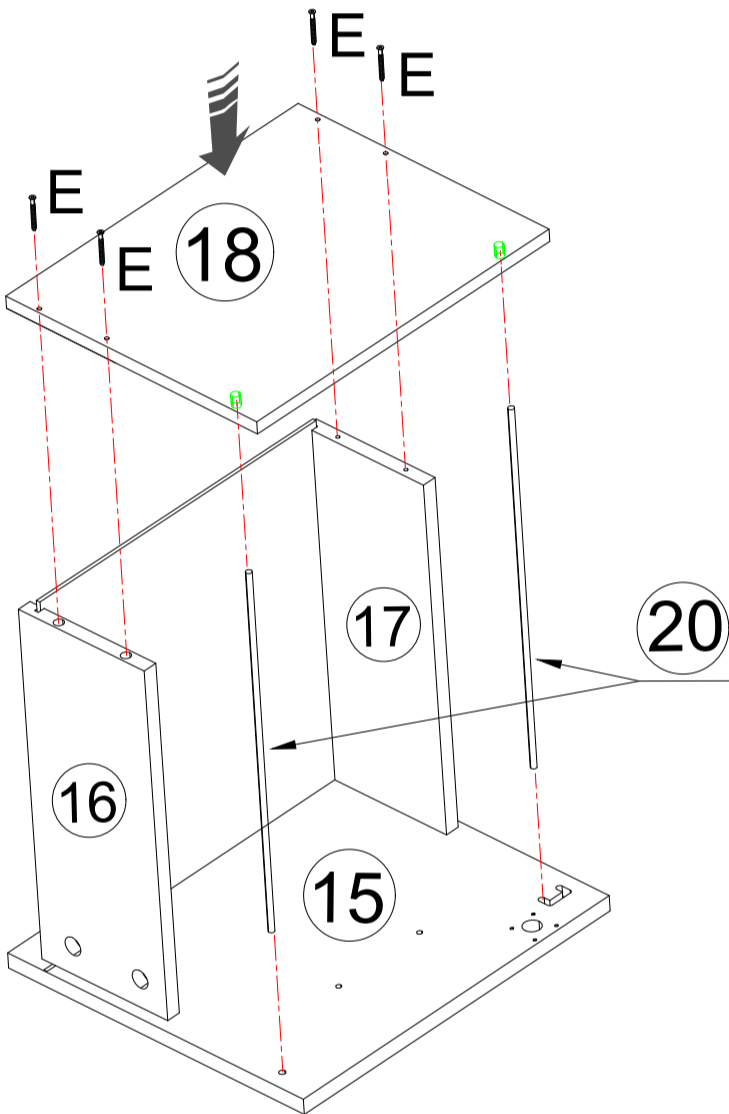

THEN: Attach the handle H to #15 with screws I.

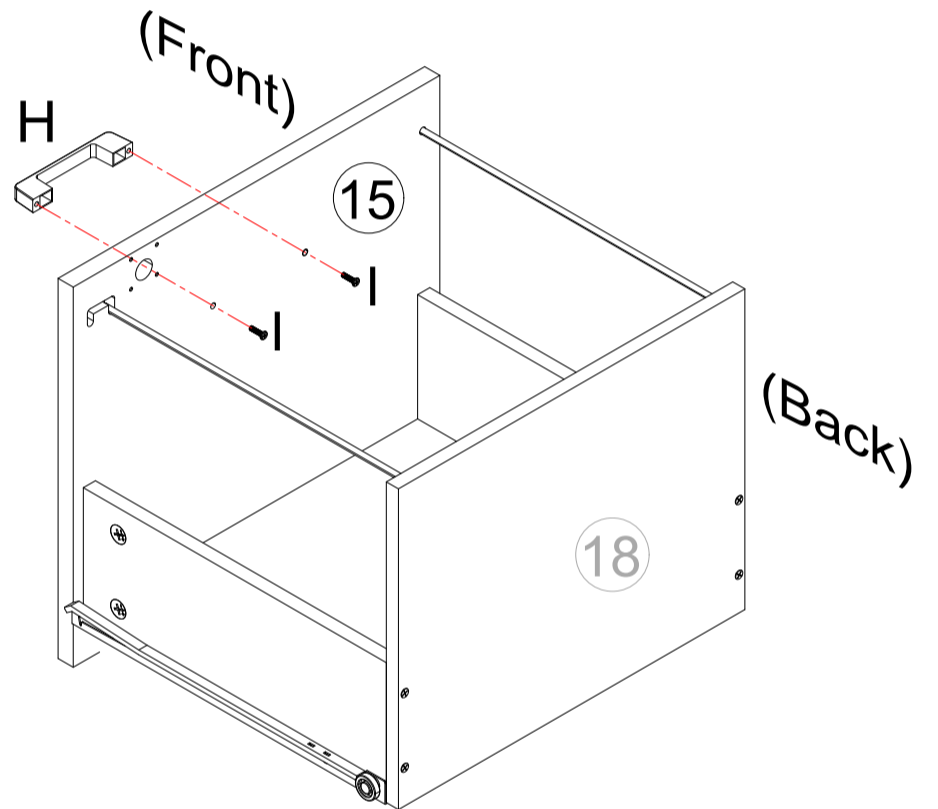

LAST: Attach the lock J to #15 on the inside with screws G, and attach the ring J to the lock on the outside.

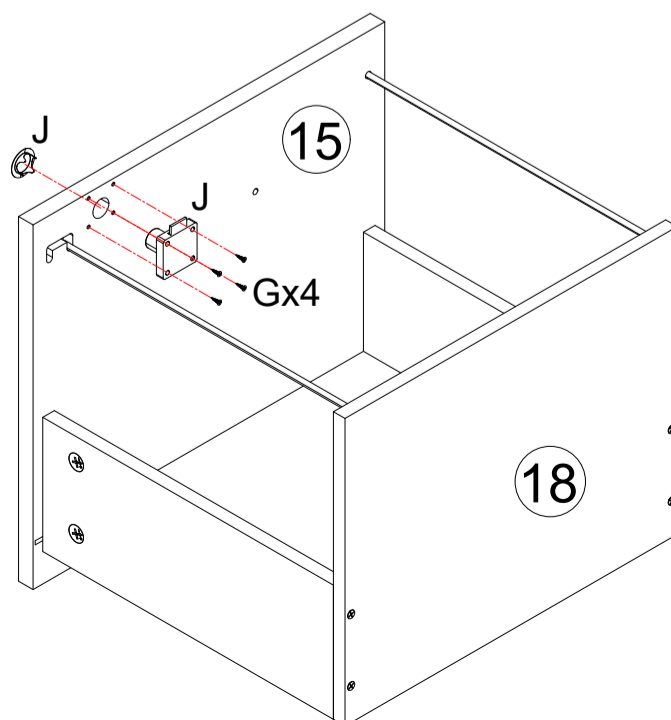
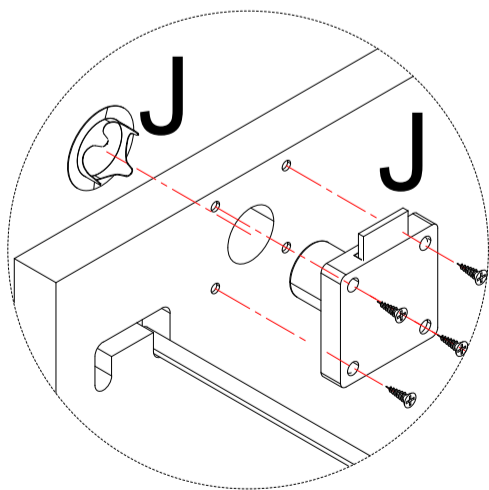

18

Attach the "L" shaped sliders #21 to the bottom of the drawer with screws F. The wheels go facing towards the back.

F M3.5x14

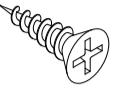

4 PCS

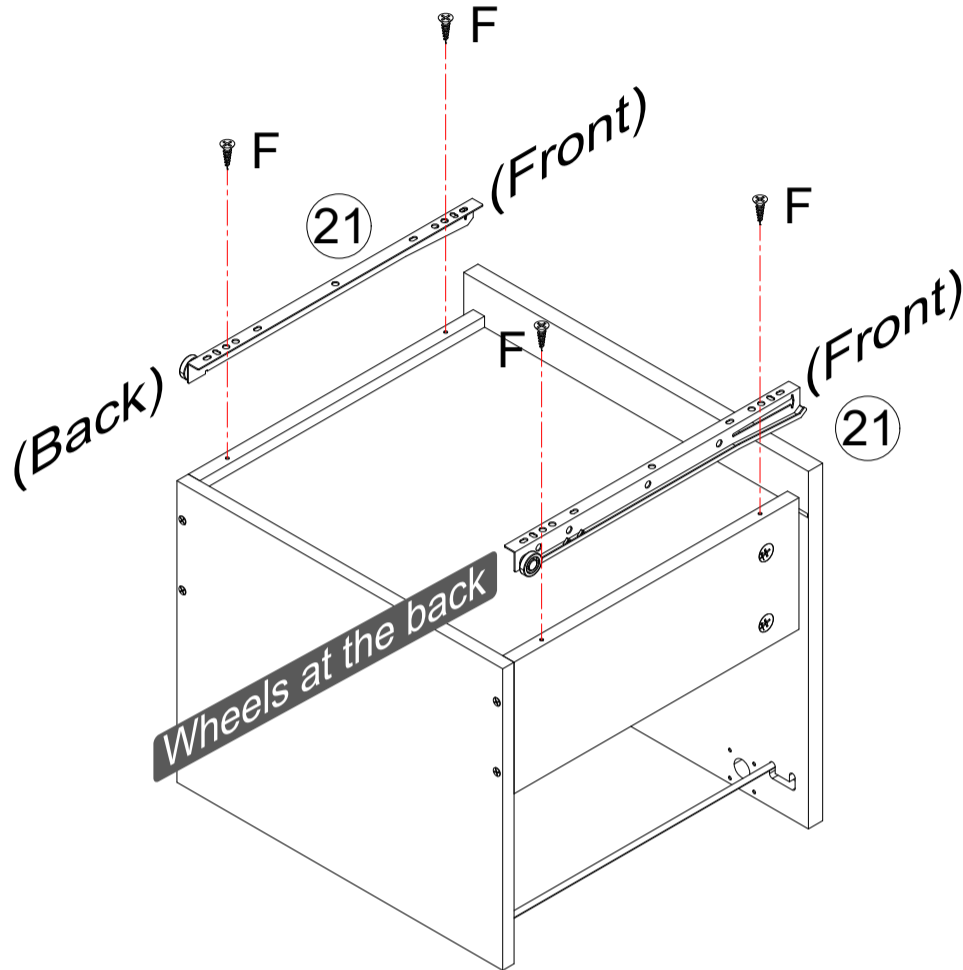

When finished, the sliders on the drawer will look like this:

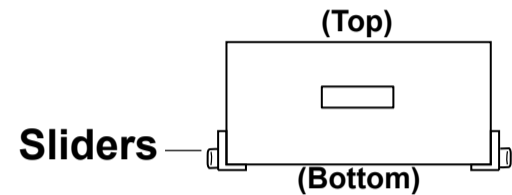

A wrong installation as below will raise the drawers 1" and won't fit!



19

FINALLY: Insert the drawers into the unit, bottom one first, then the top one, which might need to be inserted at an angle facing down.

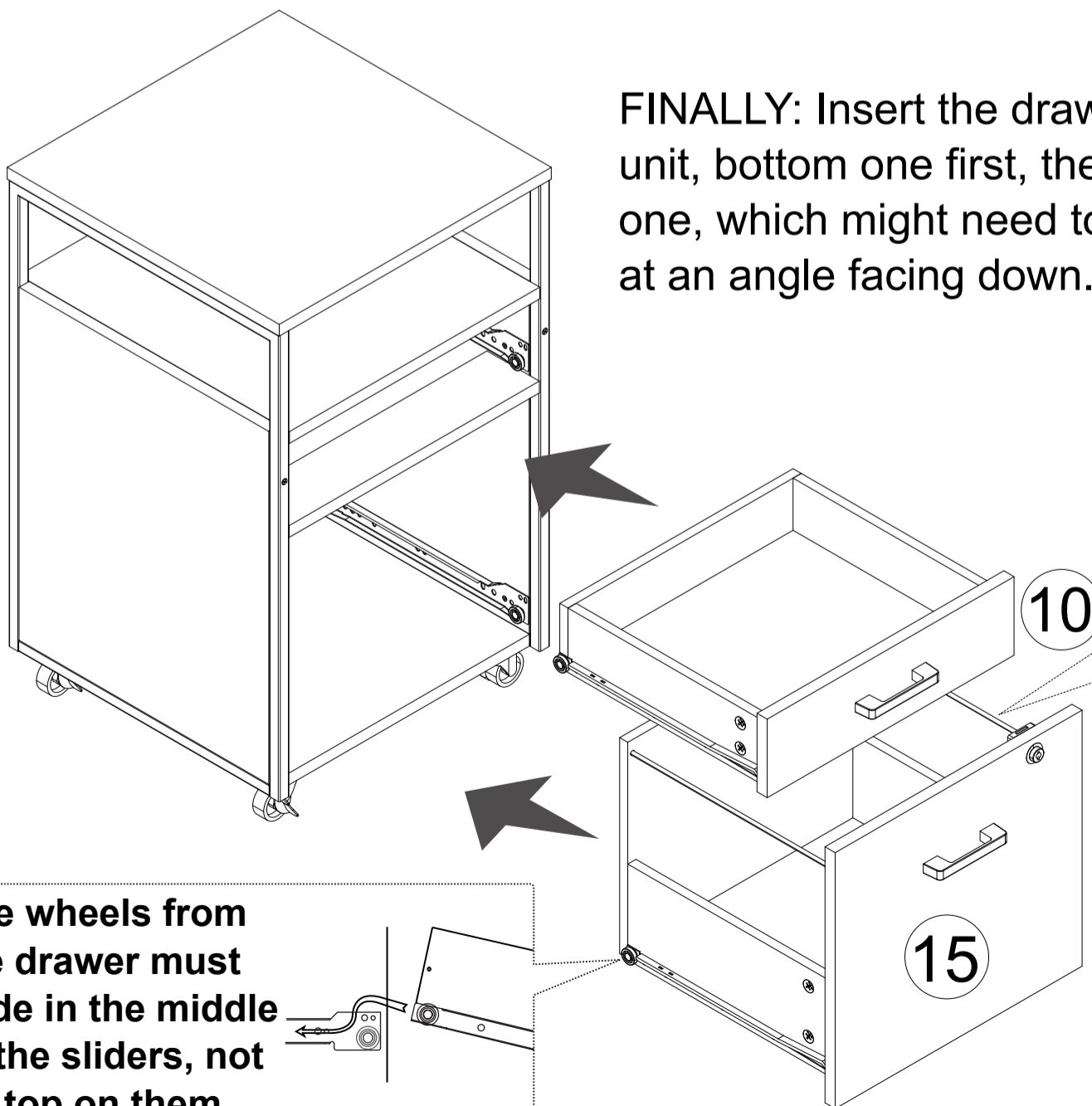

Use this slot for Int'l. A4 files

Use this slot for US Letter files.

The wheels from the drawer must slide in the middle of the sliders, not on top on them.

