

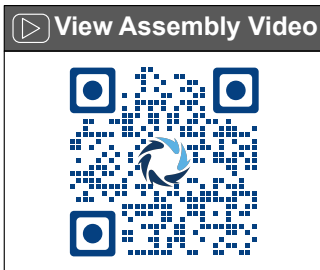



# High-Back Mesh Executive Office Chair

## ASSEMBLY INSTRUCTIONS



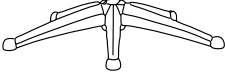
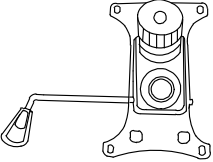

REV.7-BOL-9105-0825

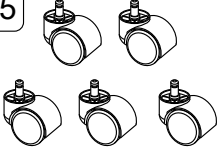
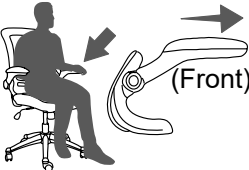
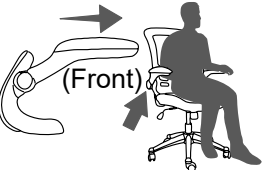
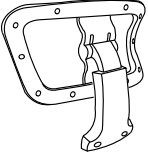

Thank you for purchasing our product!

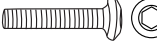
MAIN PARTS LIST		
<b>A</b> Backrest 	<b>B</b> Seat 	<b>C</b> Nylon star base 
<b>D</b> Mechanism 	<b>E</b> Lift cylinder 	<b>F</b> Casters x5 
<b>G-L</b> Left armrest 	<b>G-R</b> Right armrest 	<b>H</b> Headrest 

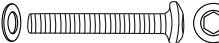
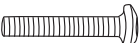
\* Right and Left defined as sitting on the chair, not by looking at it.

HARDWARE			
No.	Item		Qty.
I	M6x25		4 Pcs
J	M6x20		4 Pcs
K	M6x35 + Washer		4 Pairs
L	M6x30		4 Pcs
M	Hole covers		4 Pcs

### Tools (Included)

Allen Wrench





**STEP 1** Attach F to C, then insert E into C.

F enters into C by pressure

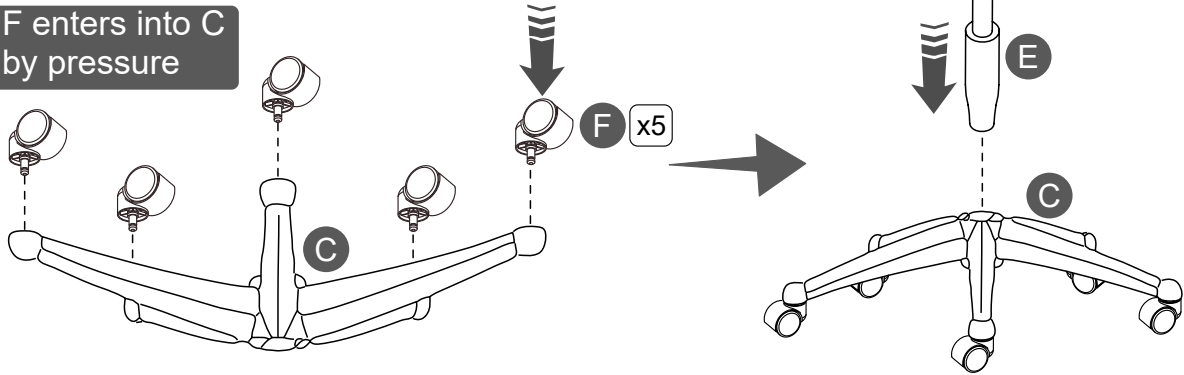

**STEP 2** Assemble D to B with J.

⚠ PAY ATTENTION TO THE ORIENTATION!

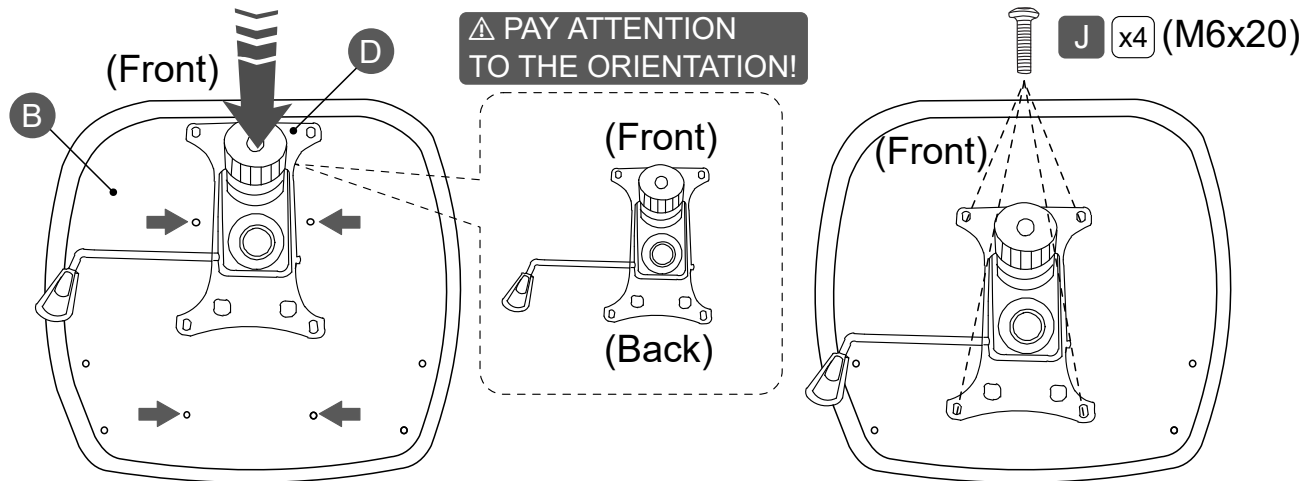

**STEP 3** Assemble G-L and G-R to B with K.

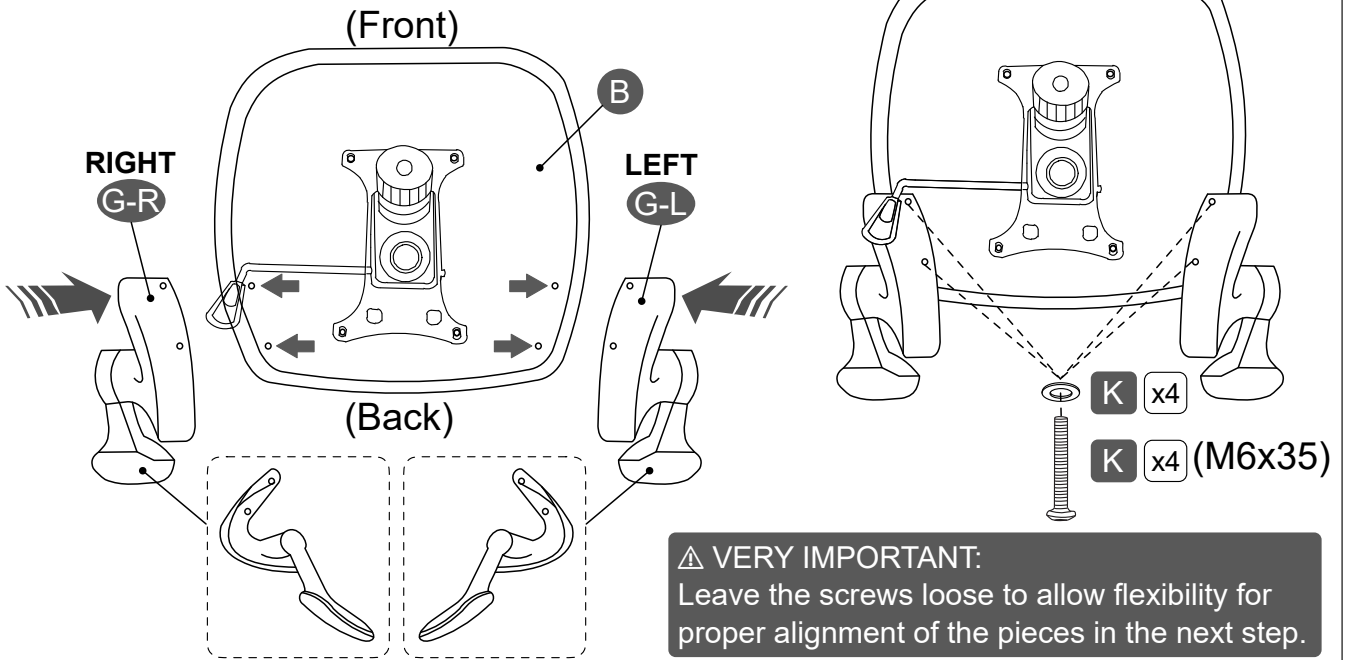

**ASSEMBLY STEPS**

**STEP 4** Join the seat to the base.

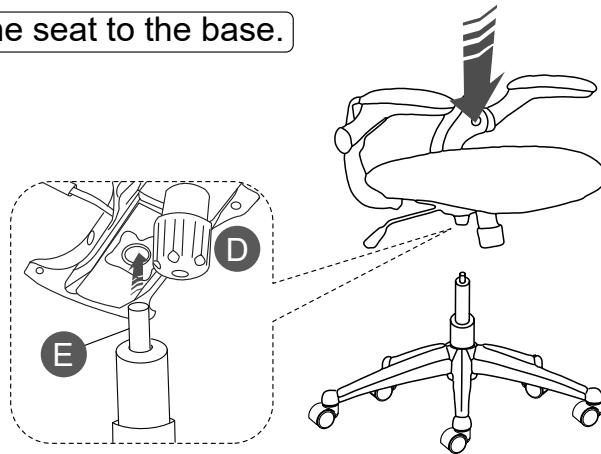

**STEP 5** Assemble A to G-L and G-R with I.

**⚠ VERY IMPORTANT:**  
Screw loosely to allow flexibility and proper alignment of the pieces.

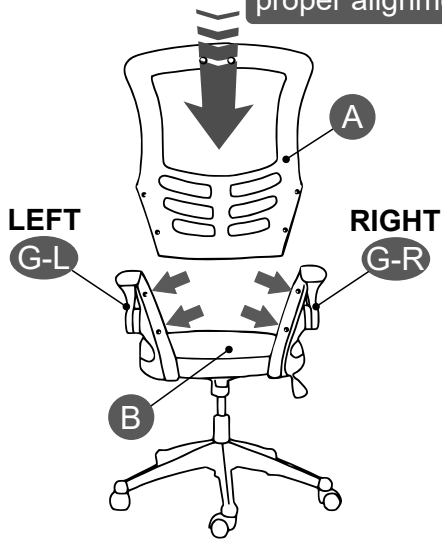

(Unit viewed from behind)

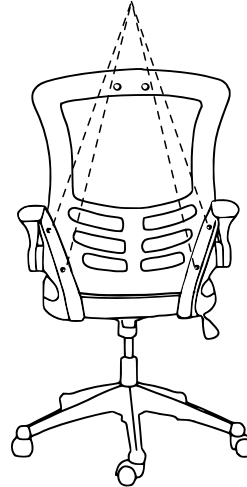
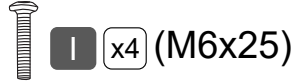

If holes don't seem to align, make sure the screws under the seat are loosened (from step 3). When finished, proceed to tighten all the screws from steps 3 and 5.

**STEP 6** Cover the armrest holes with M.

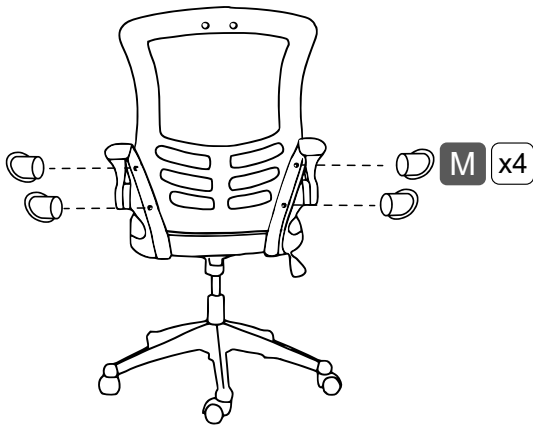

**STEP 7** Finally, attach H to A with L.

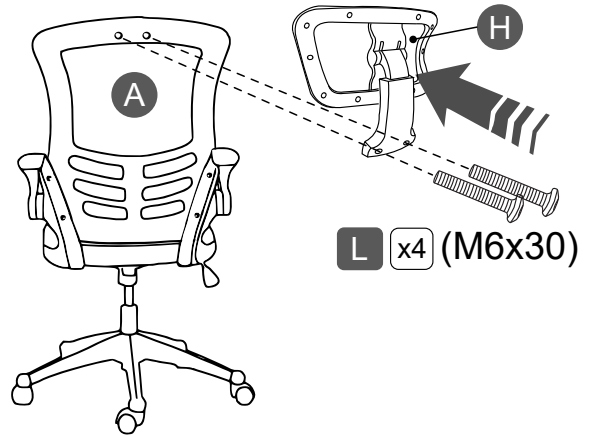

Pull knob OUT to raise/lower the headrest.

Pull Handle OUT to UNLOCK; Push Handle IN to LOCK.

Pull Handle UP.

**ADJUST**  
↑ ↓ →

**TILTING**  
🔓 → 🔒

**HEIGHT**  
↑

**FLIP-UP**  
↻

**TENSION**  
+ -

Turn the knob (+) for more tension, and (-) for less tension. Less tension means easier tilting.

**WARNINGS - Not paying attention to the following warnings could result in injuries.**

<p>220 Lbs (100 Kg)</p>	<p>Only one person at a time and refrain from sitting on the edge of the seat to prevent the chair from tipping over.</p>	<p>Do not stand on the chair.</p>
<p>Do not use the chair if the frame parts are damaged, or if any of the screws are loose or missing.</p>	<p>Do not leave babies or toddlers unattended while seated on the chair, always ensure adult supervision. Keep children from playing with the chair for their safety.</p>	

**CARE AND MAINTENANCE**

<p>Clean with a soft cloth lightly dampened in a solution of smooth soap and water.</p>	<p>Do not use solvents or abrasive materials.</p>	<p>Do not expose to direct sunlight or to extreme environmental conditions.</p>	<p>Inspect the chair thoroughly every 4 months and re-tighten the screws.</p>
---	---	---	---

