

Counter Stool

SKU# 2014091001

SKU# 2014057002

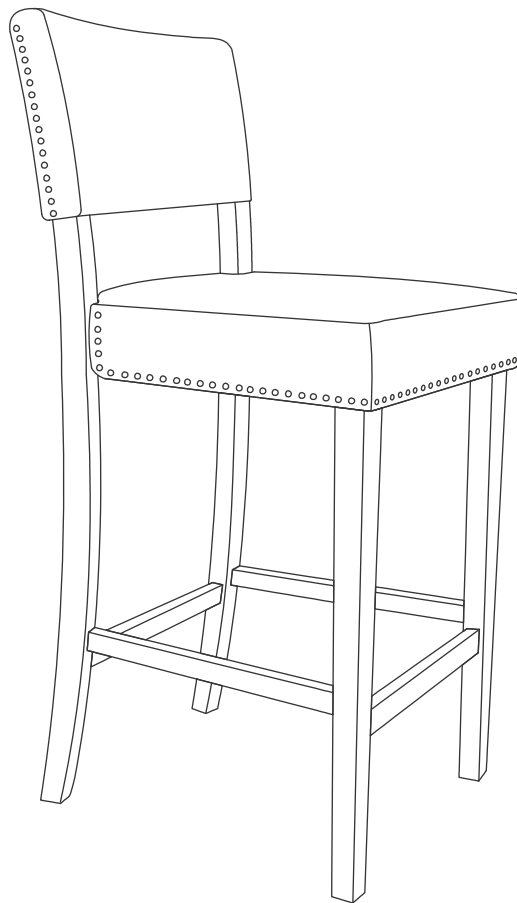

CYC-20003-VN

⚠ WARNING: To avoid serious personal injury:



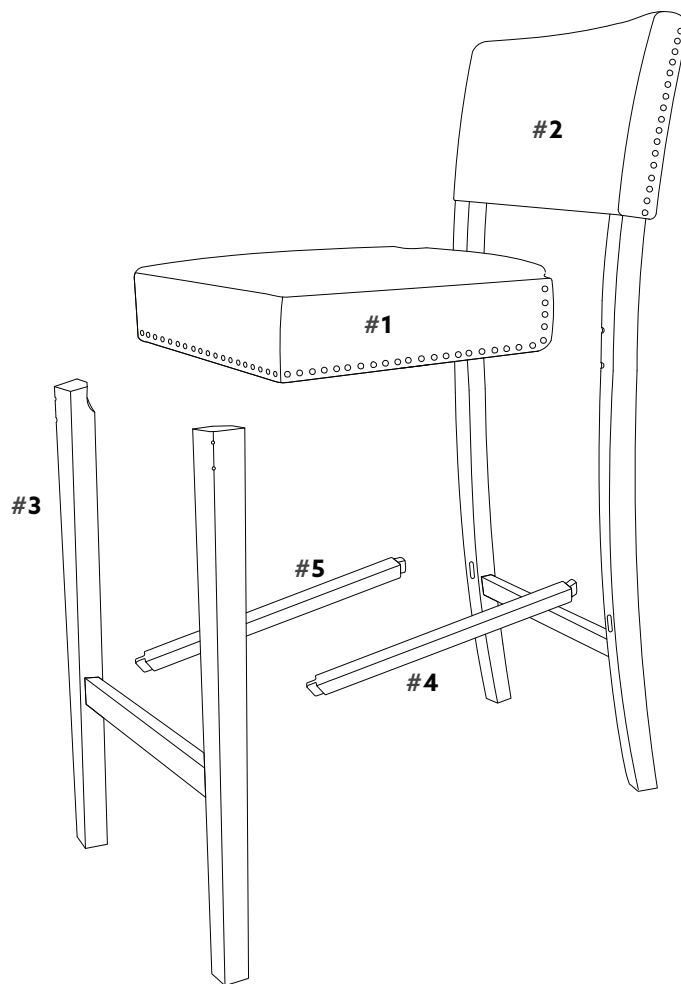

- Carefully and strictly follow assembly instructions. Improper assembly of furniture can result in structural failure, instability of the product, or tip-over.
- Monitor and carefully control the assembly components. These include small parts and hardware that may present a choking hazard to small children. Bob's furniture should be assembled only by responsible adults and children should not be involved in the assembly process.
- Where provided, wall mounting hardware should always be used as prescribed in these instructions to anchor furniture to wall. Proper use of the wall mounting hardware can significantly reduce the potential for furniture tip-over and crushing injuries.

PART LIST





#1	SEAT ASSEMBLY	01
#2	BACK ASSEMBLY	01
#3	FRONT LEG ASSEMBLY	01
#4	RIGHT SIDE STRETCHER	01
#5	LEFT SIDE STRETCHER	01

HARDWARE LIST

A		BOLT (Ø5/16" X 3")	08
B		SPRING WASHER	08
C		FLAT WASHER	08
D		WOOD SCREW (Ø4MM X 1-3/4")	04

NOTE: Find the label of "Hardware Enclosed" on one of the carton corner then follow the red ribbon to get the hardware bag.

TOOLS REQUIRED

ALLEN KEY		SUPPLIED
PHILLIP SCREWDRIVER		NOT SUPPLIED

IMPORTANT:

1. Do not tighten bolts completely until all bolts are completely lined up and inserted into holes / nuts.
2. Do not over tighten screws and bolts to avoid stripping.
3. Please use hand tools to assemble this product. Do not use power tools.
4. For ease of assembly, two adults are recommended

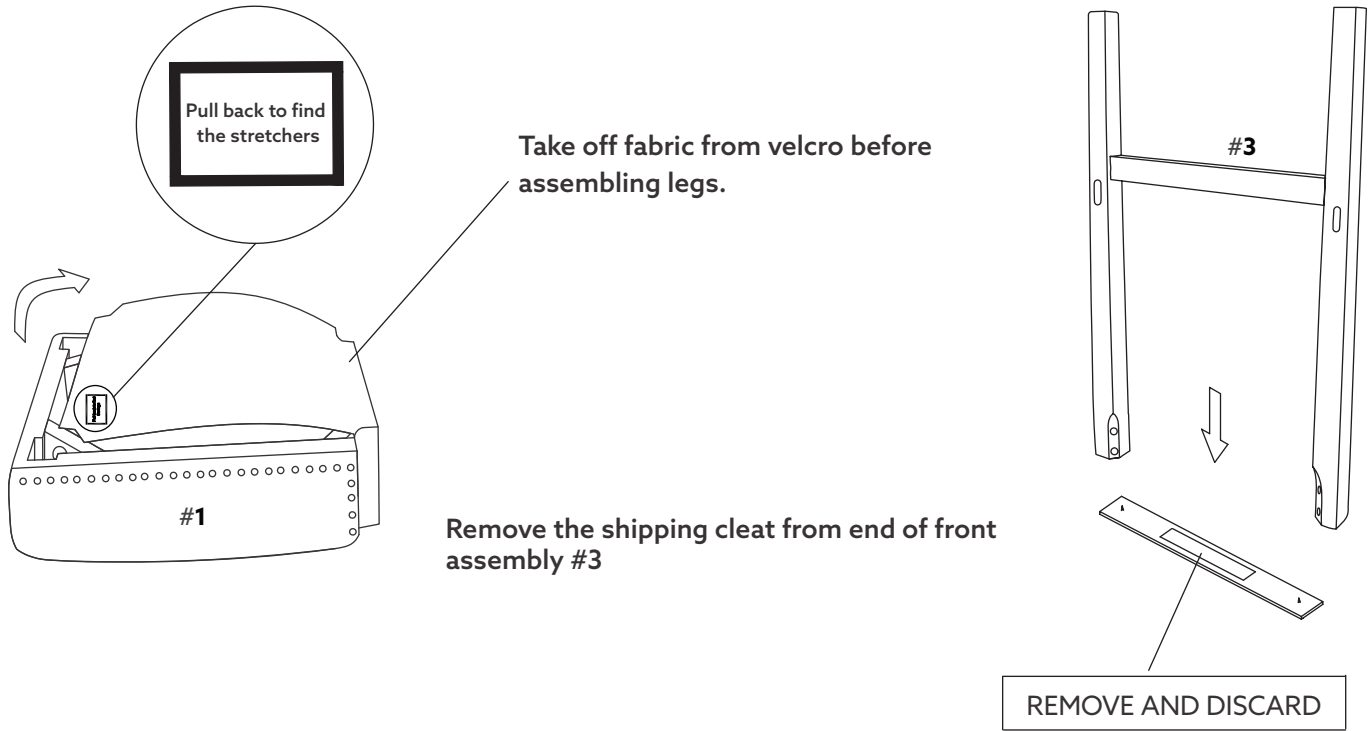

1.

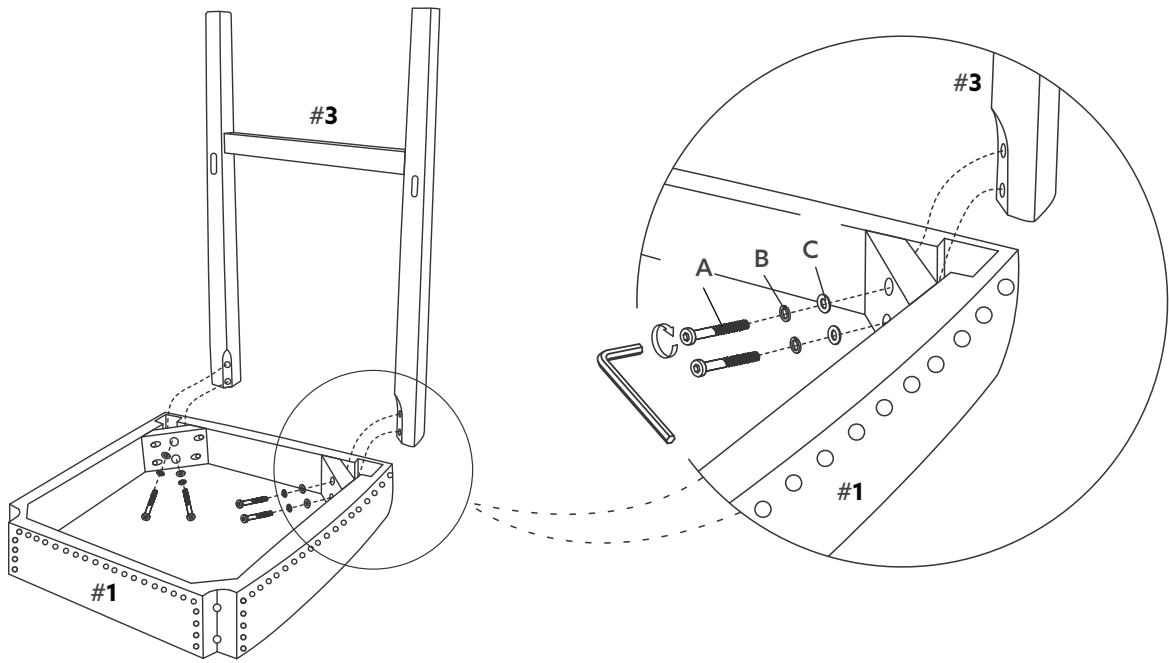

2.



Do not tighten bolts completely until all bolts are completely lined up and inserted into holes.
Be sure the legs are level then fully tighten the leg bolts!

A		04
B		04
C		04

3.

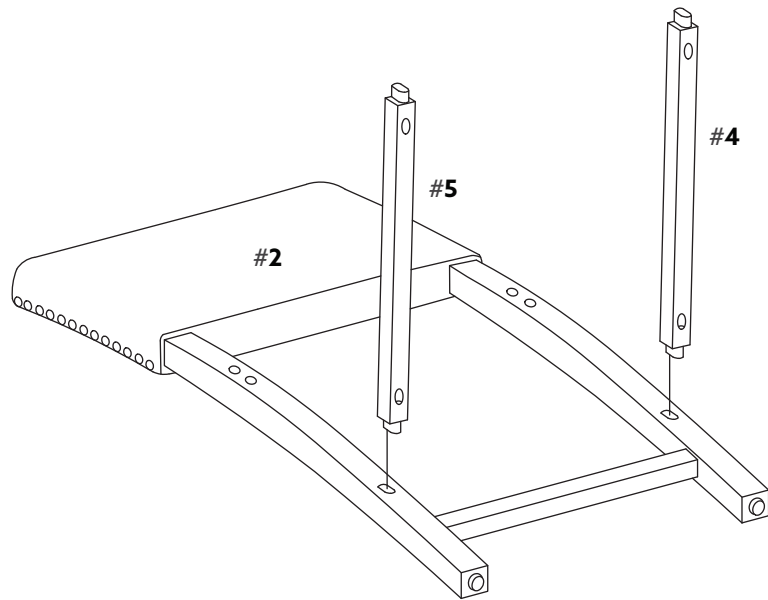

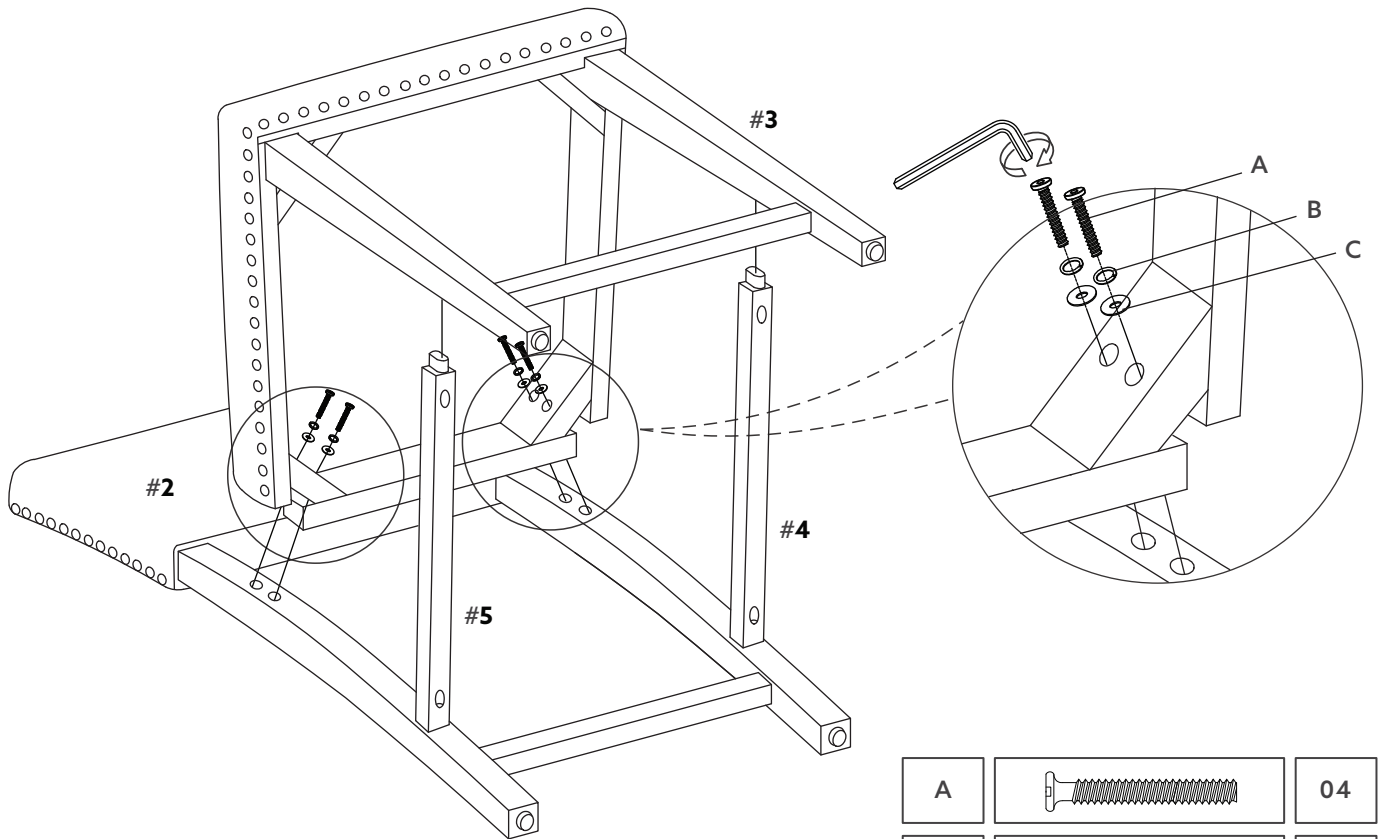

4.



Do not tighten bolts completely until all bolts are completely lined up and inserted into holes.

Be sure the legs are level then fully tighten the leg bolts!

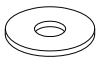
A		04
B		04
C		04

5.

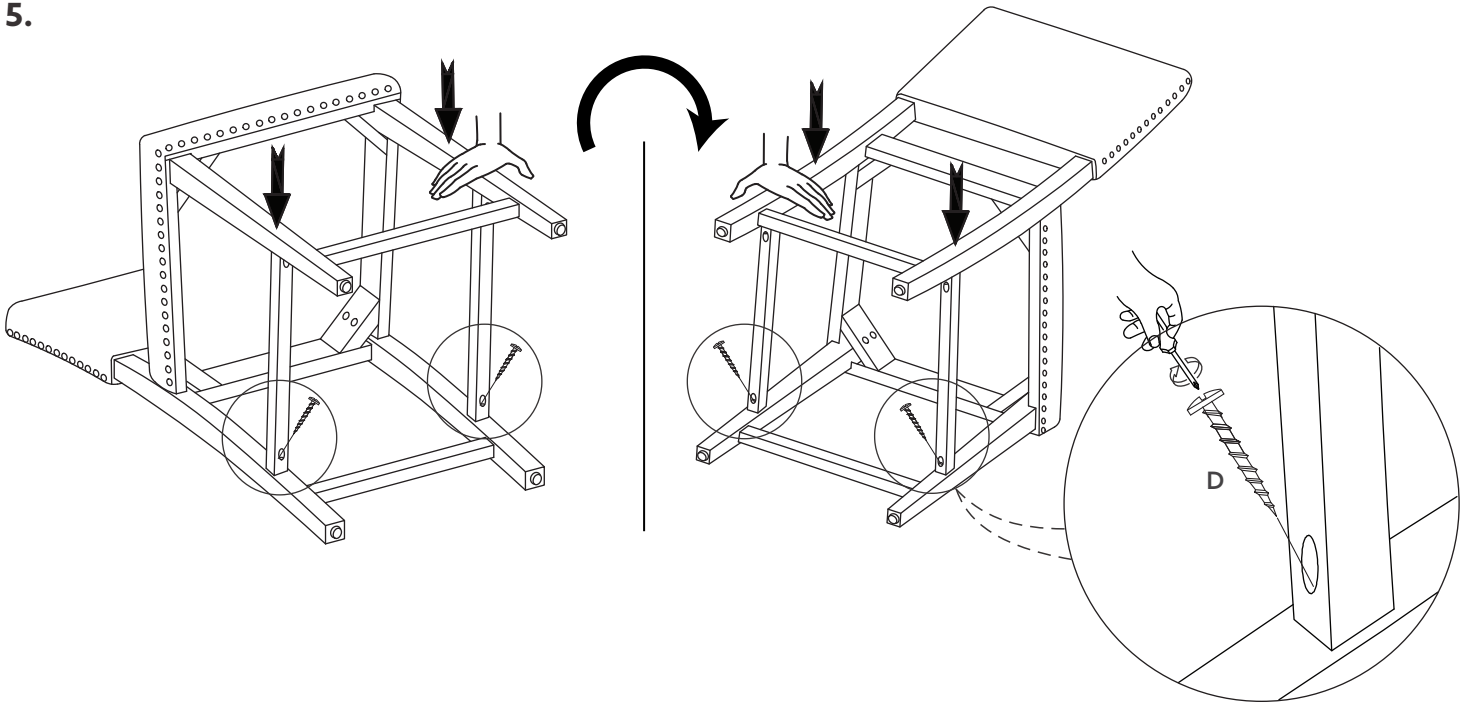

Press the legs and stretchers to make sure no gaps then tighten the screws.

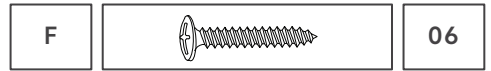

6.

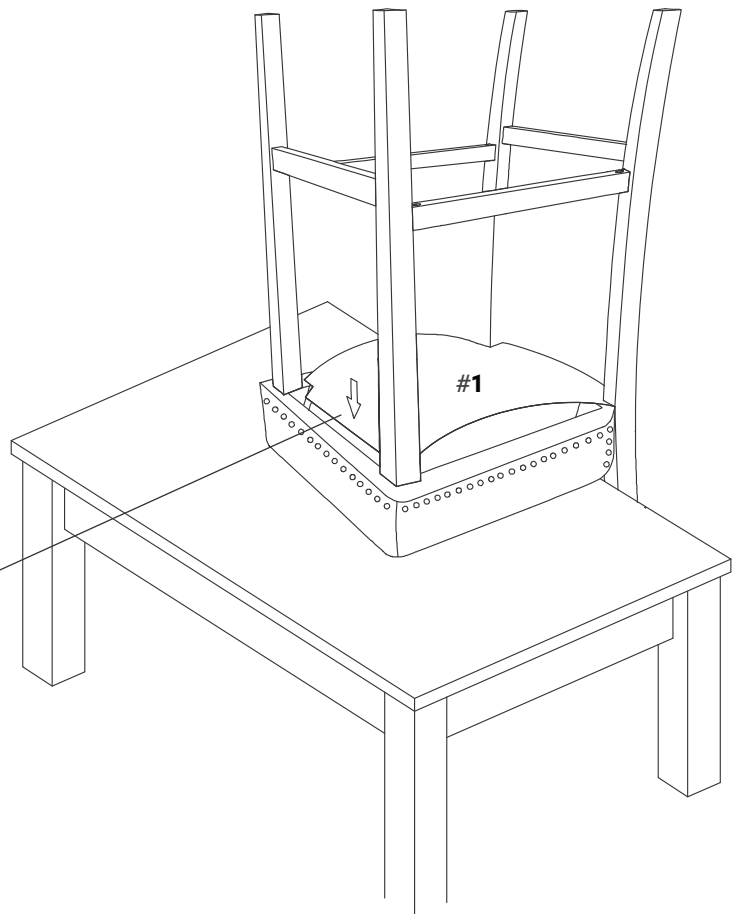

Re-attach fabric with velcro once legs are fully assembled.

Maximum Weight 350 lbs

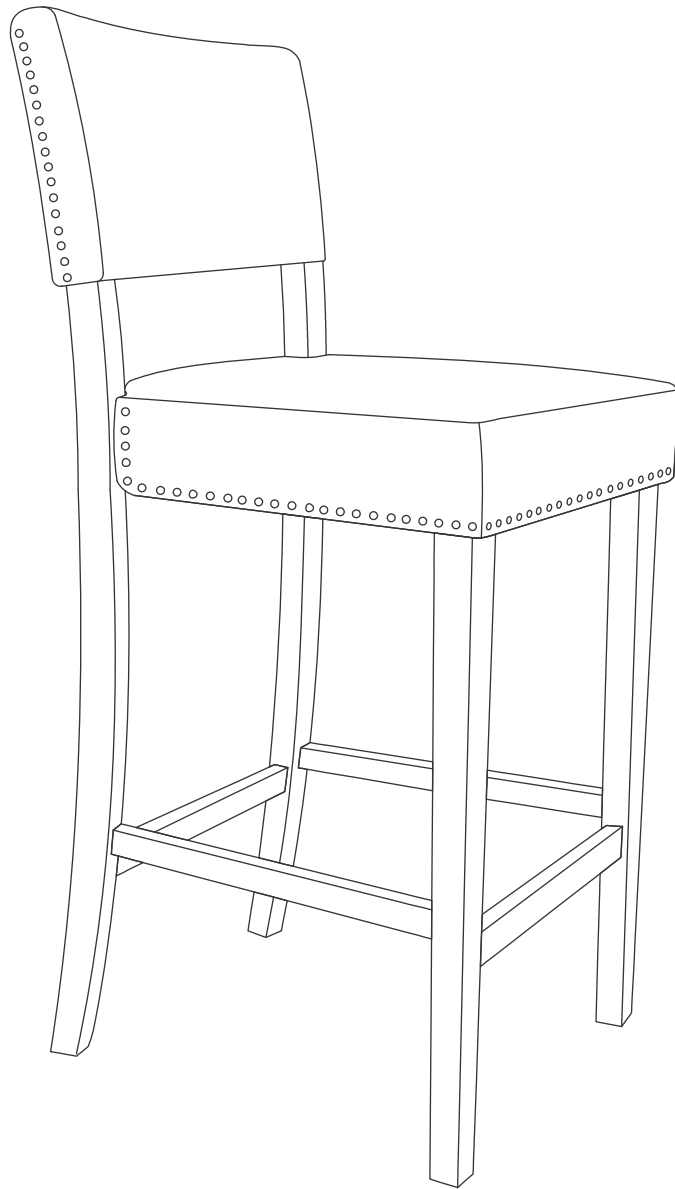

Tighten bolts firmly.