



**WARNING: To avoid serious personal injury:**

- Carefully and strictly follow assembly instructions. Improper assembly of furniture can result in structural failure, instability of the product, or tip-over.
- Monitor and carefully control the assembly components. These include small parts and hardware that may present a choking hazard to small children. Bob's furniture should be assembled only by responsible adults and children should not be involved in the assembly process.
- Where provided, wall mounting hardware should always be used as prescribed in these instructions to anchor furniture to wall. Proper use of the wall mounting hardware can significantly reduce the potential for furniture tip-over and crushing injuries.

# ASSEMBLY INSTRUCTION INSTRUCTION D' ASSEMBLAGE

ITEMNO:1135BE / GY-1  
ACCENT CHAIR

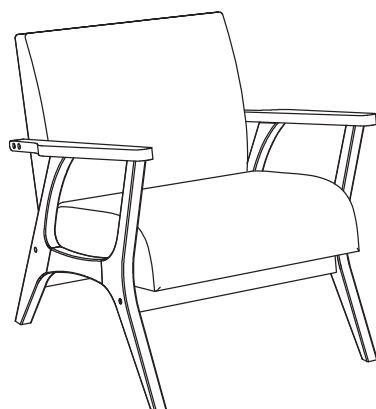

Thank you for purchasing this product. Please take time to read and follow the instructions below. Check that you have all parts and hardware before assembly. Parts apparently missing are often found in the packing materials. If you do not have all the parts listed, have your dealer contact us and they will be sent to you immediately.

Merci d'avoir acheté ce produit. Veuillez lire et suivre les instructions ci-dessous.

Vérifiez avant le montage que vous avez toutes les pièces et fixations. Les pièces qui semblent manquer se trouvent souvent dans les matériaux d'emballage. Si vous n'avez pas toutes les pièces de la liste, demandez à votre détaillant et nous vous les enverrons immédiatement.



It is recommended to install protective pads under all legs and supports to avoid damage or scratches when placing furniture on a woodfloor or other hard surface, and to limit indentation and prevent discoloration if placing on carpet.



Il est recommandé de placer des coussins protecteurs sous tous les pieds et toutes les bases des meubles pour éviter d'endommager ou d'égratigner les planchers en bois ou autres surfaces dures, et pour limiter l'empreinte et empêcher la décoloration quand les meubles reposent sur la moquette.



Hardware may loosen over time. Periodically check to make sure all connections are tight. Re-tighten if necessary.



Le matériel peut se desserrer au fil du temps. Vérifiez périodiquement que toutes les connexions sont serrées. Serrer à nouveau si nécessaire.

## PARTS LIST / LISTE DE PIÈCES

NO	DESCRIPTION	SKETCH	QTY
A	Back Rest / Dossier Seat /		1 PC
B	Siège Lsf Arm /		1 PC
C	Bras Gauche Rsf Arm / Bras-Droite		1 PC
D	Cross Bar Front Barre Transversale		1 PC
E	Cross Bar Back (Btm) Barre Transversale		1 PC
F	Cross Bar Back (Top) Barre Transversale		1 PC
G			1 PC

## HARDWARE LIST / LISTE DE QUINCAILLERIE

NO	DESCRIPTION	SKETCH	QTY
1	Jcbc Bolt / Boulon M6 x 70mm		8 PCS
2	Jcbc Bolt / Boulon M6 x 40mm		2 PCS
3	Flat Washer / Rondelle Plate M6 x 19mm		2 PCS
4	Wood Dowel M8 x 30mm		10 PCS
5	Barrel Nut M6 / Doigts En Travers M6 x 13mm		4 PCS
6	Allen Key / Clè Allen Wrench M4		1 PC

\*ABOVE HARDWARE ARE PACKED IN 1135BE / GY-1 FOR ASSEMBLY \*LE QUINCAILLERIE EST DANS 1135BE / GY-1 POUR L' ASSEMBLAGE

**\*Please assembly on smooth surface.**

**STEP 1 / ÉTAPE 1**

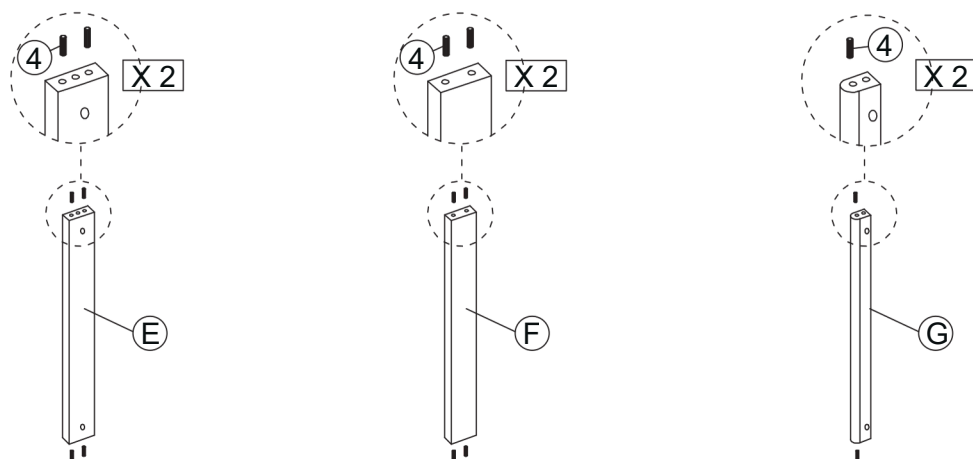

**STEP 2 / ÉTAPE 2**

**\*Do not fully tighten JCBC for this step.**

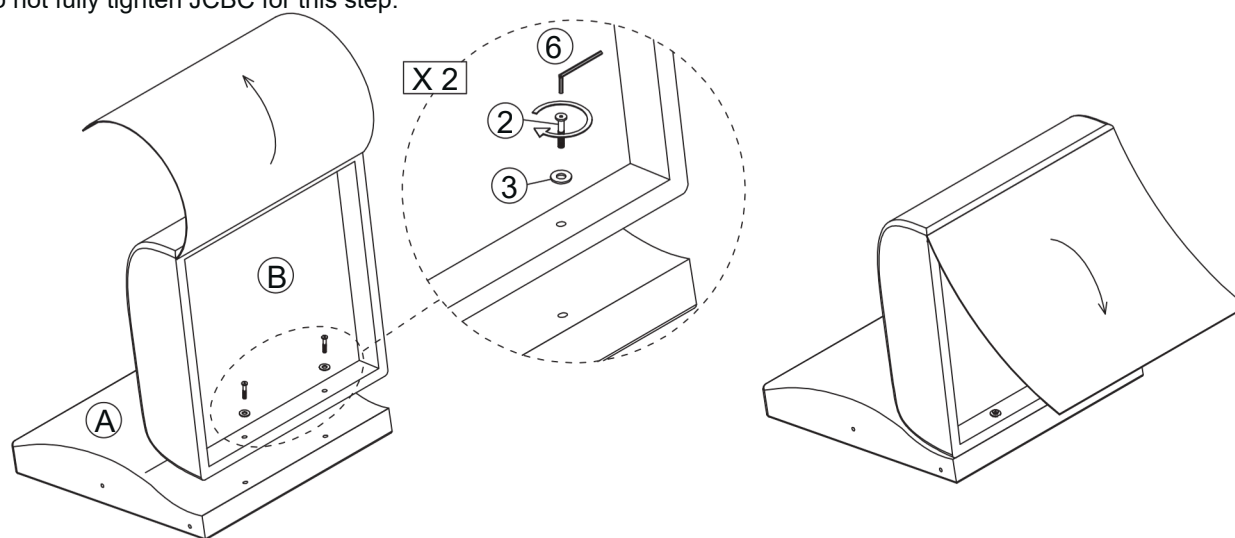

**STEP 3 / ÉTAPE 3**

**\*Do not fully tighten JCBC for this step.**

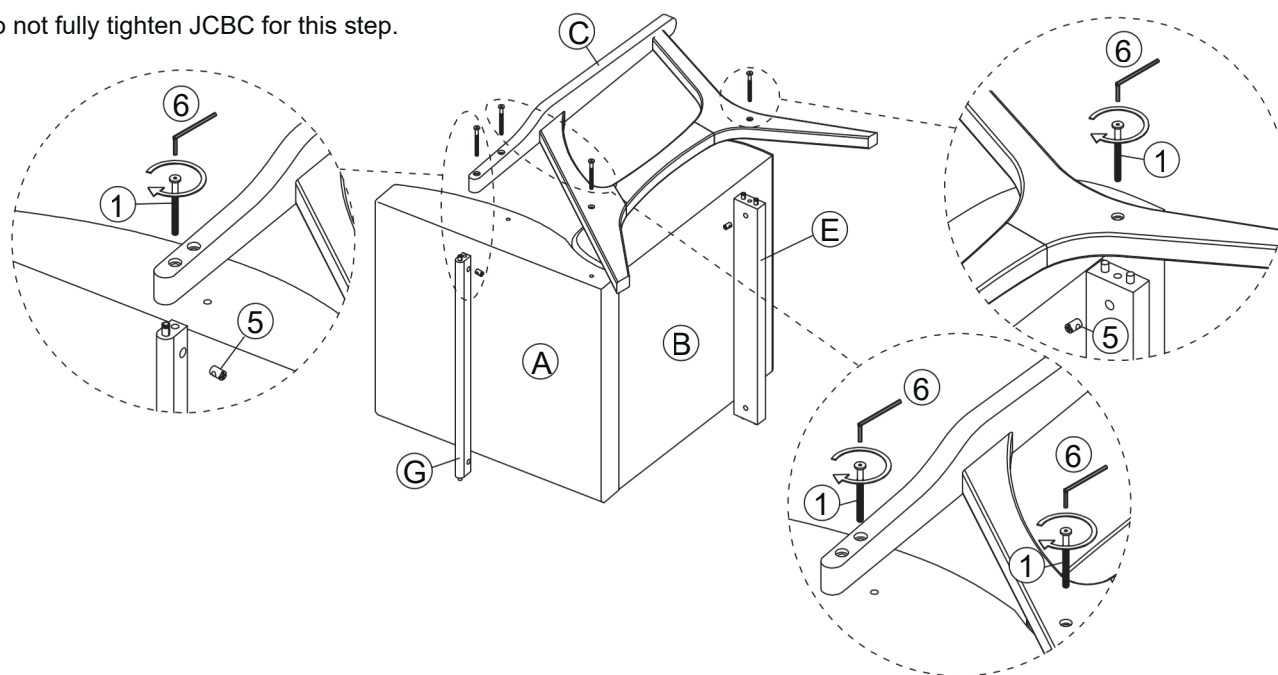

**\*Please assembly on smooth surface.**

**STEP 4 / ÉTAPE 4**

\*Do not fully tighten JCBC for this step.

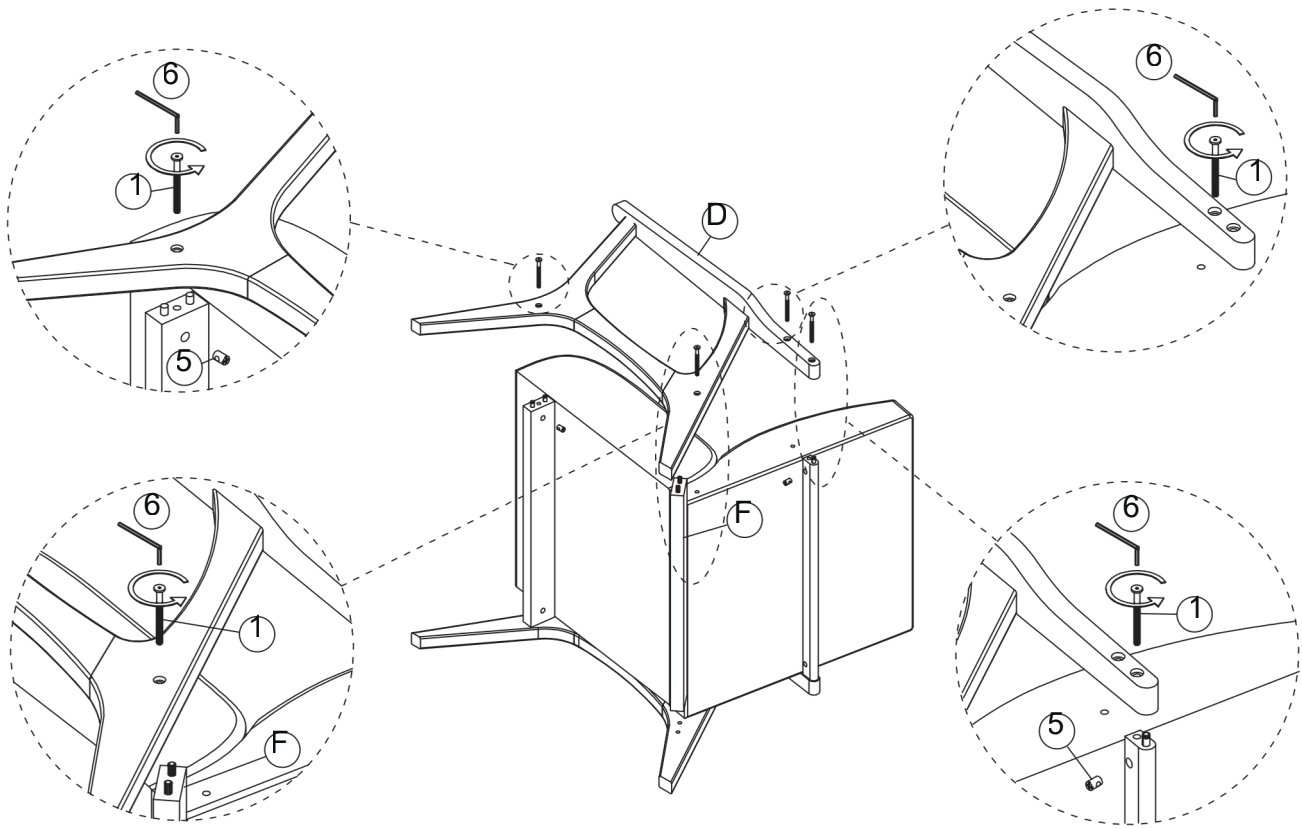

**STEP 5 / ÉTAPE 5**

\*Fully tighten JCBC bolts after all part in position.

**ASSEMBLY COMPLETE / ASSEMBLAGE COMPLETE**

