

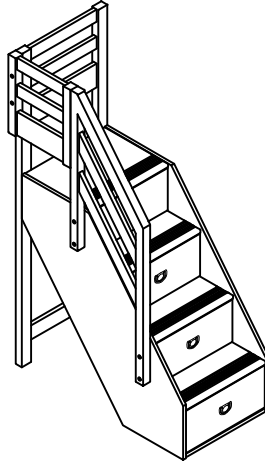

# Assembly Instructions



ITEM: 1012/1013/1014-84 CHADWICK - STORAGE STAIR DRAWER UNIT SKU#10002487004/10002488004/10002485004  
 ITEM: 1012/1013/1014-85 CHADWICK - STORAGE STAIR HAND RAIL, BACK & END PANEL SKU#10002487002/10002488002/10002485002







**⚠ WARNING:** To avoid serious personal injury:

- Carefully and strictly follow assembly instructions. Improper assembly of furniture can result in structural failure, instability of the product, or tip-over.
- Monitor and carefully control the assembly components. These include small parts and hardware that may present a choking hazard to small children. Bob's furniture should be assembled only by responsible adults and children should not be involved in the assembly process.
- Where provided, wall mounting hardware should always be used as prescribed in these instructions to anchor furniture to walls. Proper use of the wall mounting hardware can significantly reduce the potential for furniture tip-over and crushing injuries.

Code	Parts	Qty
A	Storage Stair Drawer Unit 	1pc

Code	Parts	Qty
B	Back Panel 	1pc
C	Hand Rail 	1pc
D	End Panel 	1pc

Code	Hardware	Qty
1	Bolt Ø1/4"*15*2-1/4" 	12pcs
2	L Metal Bracket 117*20*2mm 	2pcs
3	Allen Key 4mm 	1pc
4	Screw M3.5*1" 	6pcs

**TOOLS REQUIRED ( NOT PROVIDED )**

Phillips Screwdriver 

**Hardware Pack Location(s):**

ITEM: 1012/1013/1014-85 CHADWICK - STORAGE STAIR HAND RAIL, BACK & END PANEL SKU#10002487002/10002488002/10002485002

# Assembly Instructions

**BOB'S**  
Discount Furniture.

ITEM: 1012/1013/1014-84 CHADWICK - STORAGE STAIR DRAWER UNIT

SKU#10002487004/10002488004/10002485004

ITEM: 1012/1013/1014-85 CHADWICK - STORAGE STAIR HAND RAIL,  
BACK & END PANEL

SKU#10002487002/10002488002/10002485002

## STEP 1

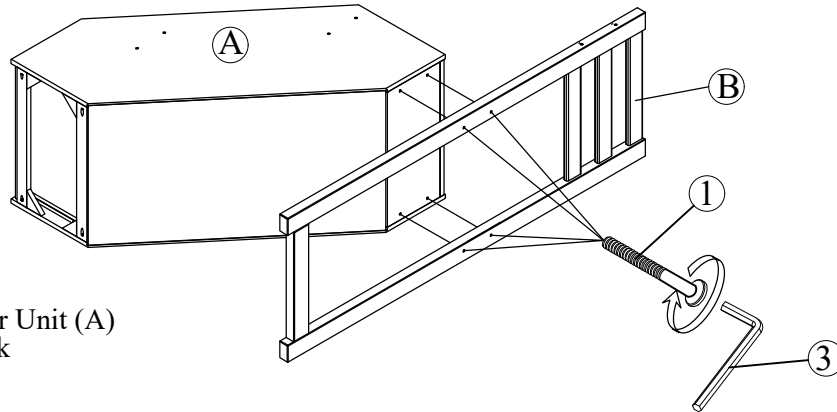

Place Storage Stair Drawer Unit (A)  
on the side and attach Back  
Panel (B) using Bolts (1).

## STEP 2

### OPTION A - LEFT

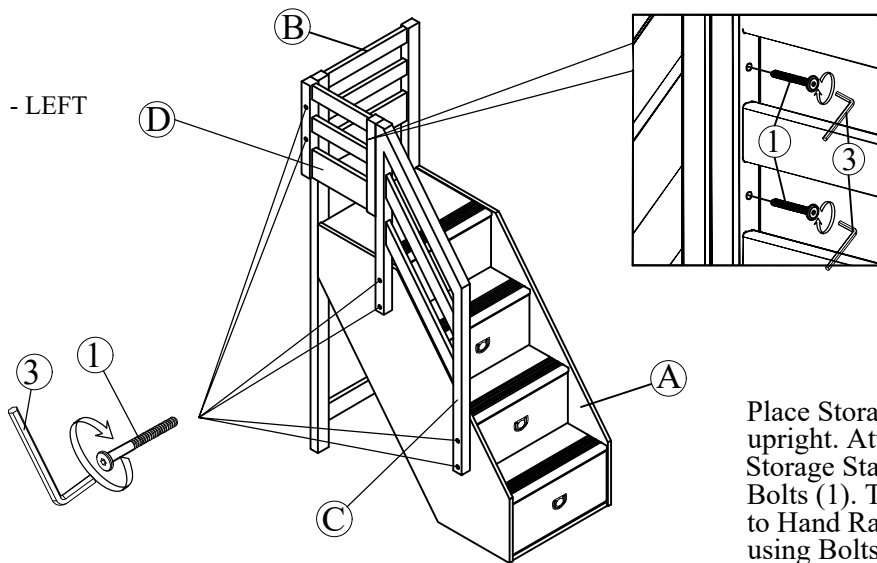

Place Storage Stair Drawer Unit (A)  
upright. Attach Hand Rail (C) to  
Storage Stair Drawer Unit (A) using  
Bolts (1). Then attach End Panel (D)  
to Hand Rail (C) and Back Panel (B)  
using Bolts (1).

### OPTION B - RIGHT

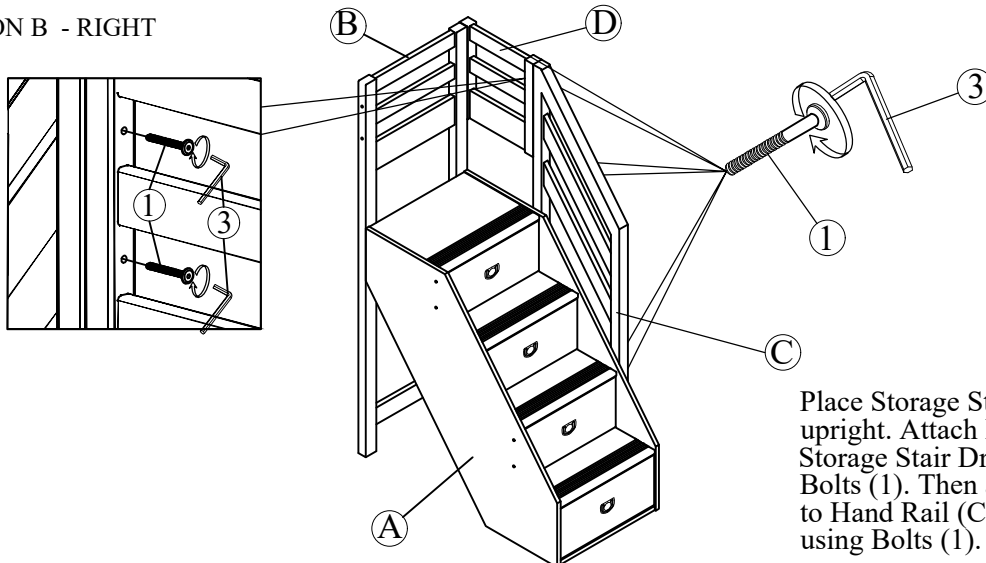

Place Storage Stair Drawer Unit (A)  
upright. Attach Hand Rail (C) to  
Storage Stair Drawer Unit (A) using  
Bolts (1). Then attach End Panel (D)  
to Hand Rail (C) and Back Panel (B)  
using Bolts (1).

## Hardware Pack Location(s):

ITEM: 1012/1013/1014-85 CHADWICK - STORAGE STAIR HAND RAIL,  
BACK & END PANEL

SKU#10002487002/10002488002/10002485002

# Assembly Instructions

**BOB'S**  
Discount Furniture.

ITEM: 1012/1013/1014-84 CHADWICK - STORAGE STAIR DRAWER UNIT

SKU#10002487004/10002488004/10002485004

ITEM: 1012/1013/1014-85 CHADWICK - STORAGE STAIR HAND RAIL,  
BACK & END PANEL

SKU#10002487002/10002488002/10002485002

## STEP 3

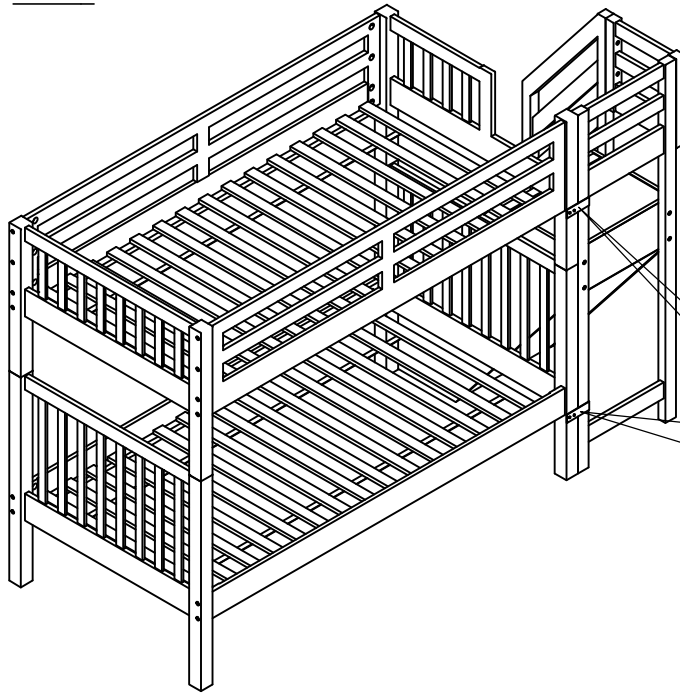

### OPTION A - LEFT

Attach assembled Staircase to Bunkbed with L Metal Brackets (2) and Screws (4) underneath each siderail as shown.

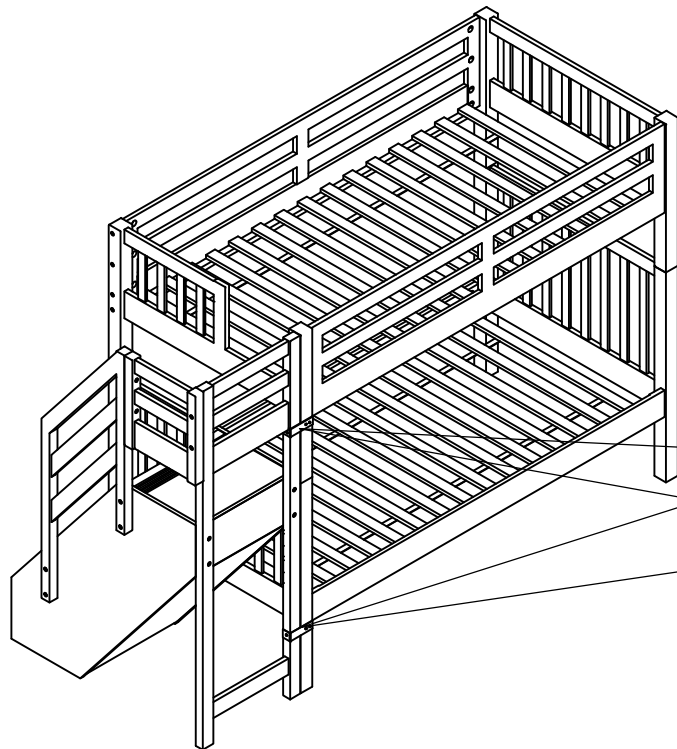
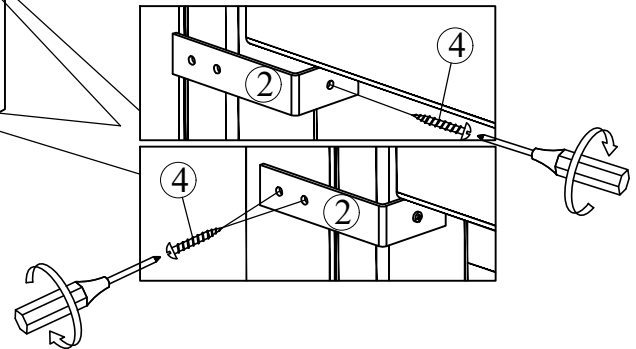

### OPTION B - RIGHT

Attach assembled Staircase to Bunkbed with L Metal Brackets (2) and Screws (4) underneath each siderail as shown.

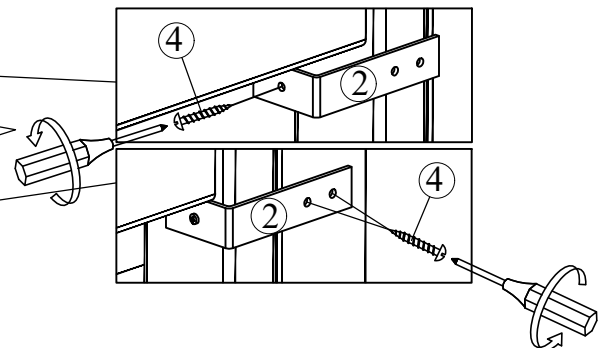

## Hardware Pack Location(s):

ITEM: 1012/1013/1014-85 CHADWICK - STORAGE STAIR HAND RAIL,  
BACK & END PANEL

SKU#10002487002/10002488002/10002485002

# Assembly Instructions

**BOB'S**  
Discount Furniture.

ITEM: 1012/1013/1014-77  
ITEM: 1012/1013/1014-78  
ITEM: 1012/1013/1014-79  
ITEM: 1012/1013/1014-82

CHADWICK - TWIN/TWIN UPPER HBFB  
CHADWICK - TWIN/TWIN LOWER HBFB  
CHADWICK - TWIN SLAT ROLL (15PCS/SET PER BOX)  
CHADWICK - UPPER & LOWER SIDE RAIL & GUARDRAIL

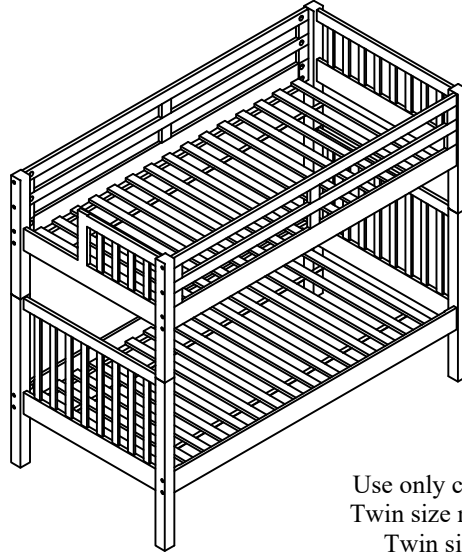

SKU#10002487006/10002488006/10002485007  
SKU#10002487003/10002488003/10002485003  
SKU#10002485006  
SKU#10002487007/10002488007/10002485008





Use only correct mattress dimensions and Bunkie board:  
Twin size mattress-74" - 75" long and 37.5" - 38.5" wide  
Twin size Bunkie board - 74" long and 37.5" wide

**⚠ WARNING:** To avoid serious personal injury:

- Carefully and strictly follow assembly instructions. Improper assembly of furniture can result in structural failure, instability of the product, or tip-over.
- Monitor and carefully control the assembly components. These include small parts and hardware that may present a choking hazard to small children. Bob's furniture should be assembled only by responsible adults and children should not be involved in the assembly process. This item should be assembled by at least 2 adults.
- Where provided, wall mounting hardware should always be used as prescribed in these instructions to anchor furniture to walls. Proper use of the wall mounting hardware can significantly reduce the potential for furniture tip-over and crushing injuries.



Code	Upper HB/FB Parts	Qty
A	Upper Headboard 	1pc
B	Upper Footboard 	1pc

Code	Lower HB/FB Parts	Qty
C	Lower Headboard/Footboard 	2pcs

Code	Side Rail Parts	Qty
D	Guard Side Rail 	2pcs
E	Side Rail 	2pcs

Code	Slat Parts	Qty
F	Slat Roll(15pcs/set) 	2sets

Code	Hardware (Packed In Upper HB/FB Carton)	Qty
1	Metal Dowel Ø2/5"*3-1/2" 	4pcs

Code	Hardware (Packed In Side Rail Carton)	Qty
2	Bolt Ø1/4"*15*4-1/4" 	24pcs
3	Crescent Insert 1/4" 	24pcs
4	Allen Key 4mm 	2pcs

Code	Hardware (Packed In Slat Carton)	Qty
5	Screw M4*1-1/4" 	60pcs /2sets

**TOOLS REQUIRED ( NOT PROVIDED )**

Phillips Screwdriver 

**Hardware Pack Location(s):**

ITEM: 1012/1013/1014-77  
ITEM: 1012/1013/1014-79  
ITEM: 1012/1013/1014-82

CHADWICK - TWIN/TWIN UPPER HBFB  
CHADWICK - TWIN SLAT ROLL (15PCS/SET PER BOX)  
CHADWICK - UPPER & LOWER SIDE RAIL & GUARDRAIL

SKU#10002487006/10002488006/10002485007  
SKU#10002485006  
SKU#10002487007/10002488007/10002485008

# Assembly Instructions

**BOB'S**  
Discount Furniture.

ITEM: 1012/1013/1014-77  
ITEM: 1012/1013/1014-78  
ITEM: 1012/1013/1014-79  
ITEM: 1012/1013/1014-82

CHADWICK - TWIN/TWIN UPPER HBFB  
CHADWICK - TWIN/TWIN LOWER HBFB  
CHADWICK - TWIN SLAT ROLL (15PCS/SET PER BOX)  
CHADWICK - UPPER & LOWER SIDE RAIL & GUARDRAIL

SKU#10002487006/10002488006/10002485007  
SKU#10002487003/10002488003/10002485003  
SKU#10002485006  
SKU#10002487007/10002488007/10002485008

## STEP 1

### OPTION A - LEFT

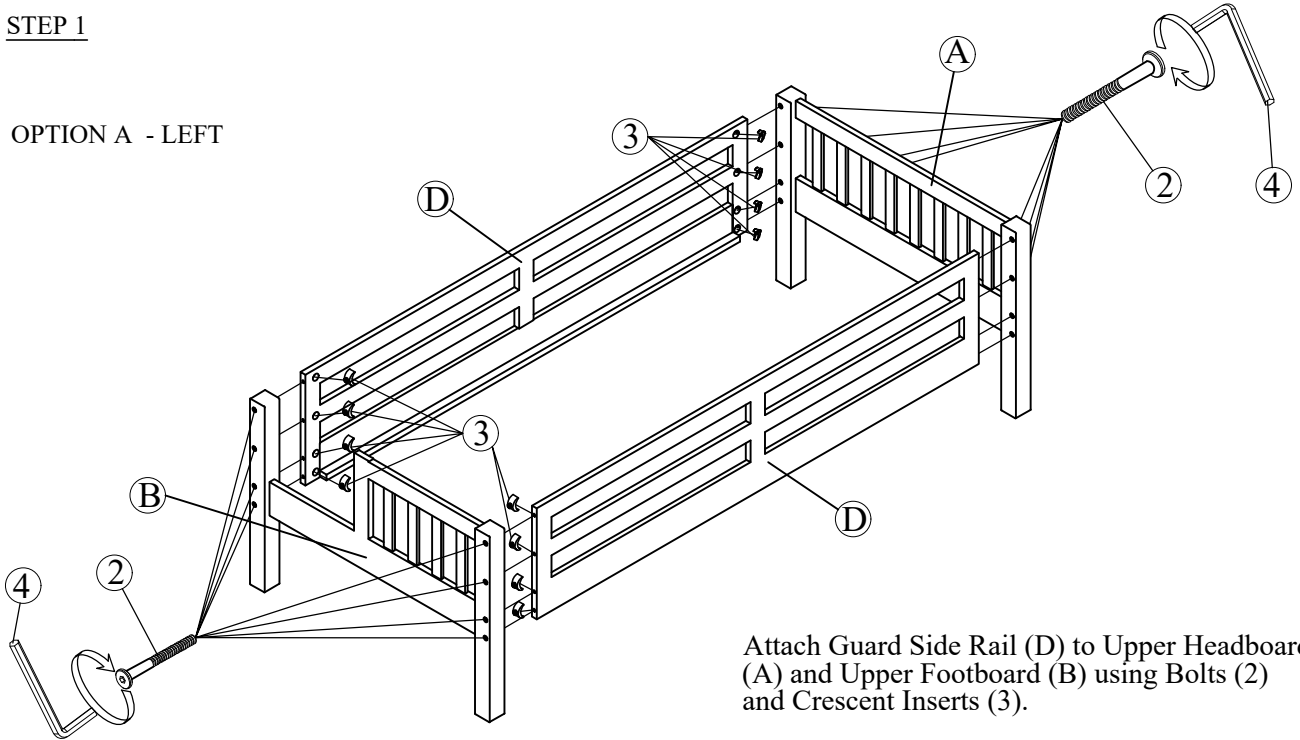

Attach Guard Side Rail (D) to Upper Headboard (A) and Upper Footboard (B) using Bolts (2) and Crescent Inserts (3).

### OPTION B - RIGHT

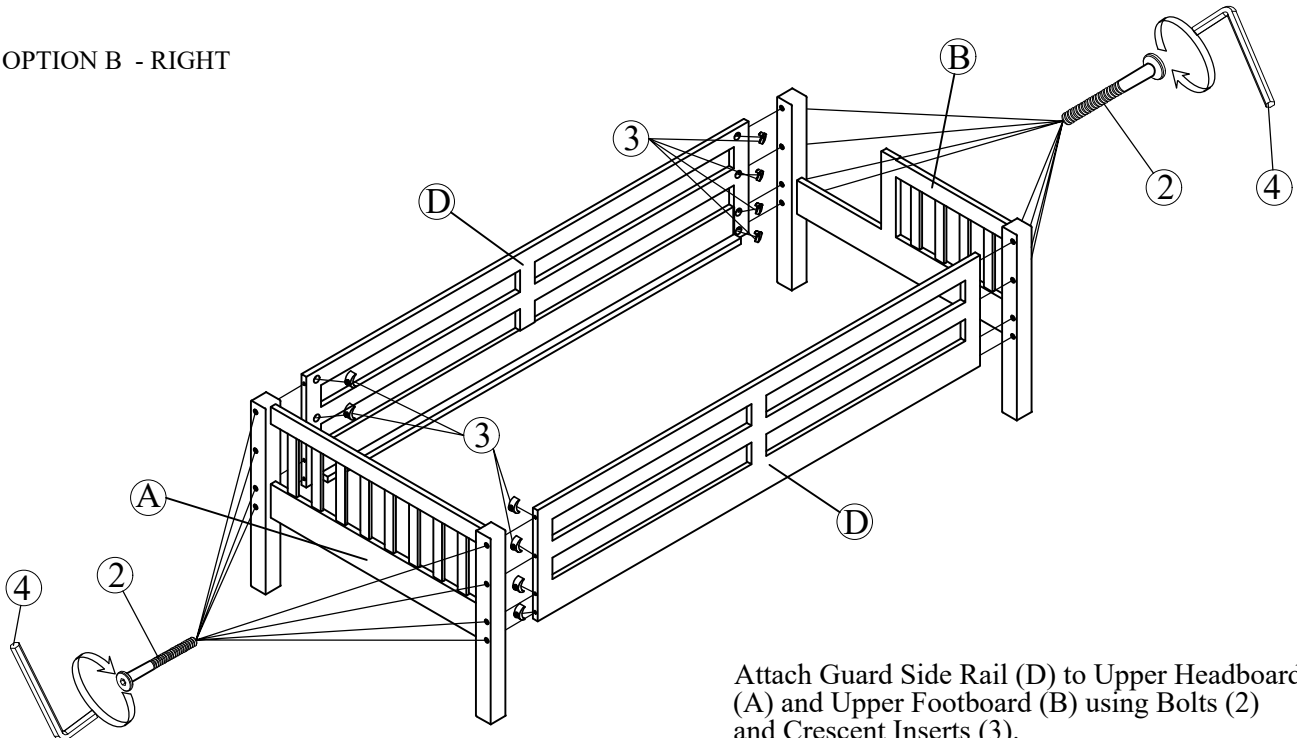

Attach Guard Side Rail (D) to Upper Headboard (A) and Upper Footboard (B) using Bolts (2) and Crescent Inserts (3).

## Hardware Pack Location(s):

ITEM: 1012/1013/1014-77  
ITEM: 1012/1013/1014-79  
ITEM: 1012/1013/1014-82

CHADWICK - TWIN/TWIN UPPER HBFB  
CHADWICK - TWIN SLAT ROLL (15PCS/SET PER BOX)  
CHADWICK - UPPER & LOWER SIDE RAIL & GUARDRAIL

SKU#10002487006/10002488006/10002485007  
SKU#10002485006  
SKU#10002487007/10002488007/10002485008

# Assembly Instructions

**BOB'S**  
Discount Furniture.

ITEM: 1012/1013/1014-77  
ITEM: 1012/1013/1014-78  
ITEM: 1012/1013/1014-79  
ITEM: 1012/1013/1014-82

CHADWICK - TWIN/TWIN UPPER HBFB  
CHADWICK - TWIN/TWIN LOWER HBFB  
CHADWICK - TWIN SLAT ROLL (15PCS/SET PER BOX)  
CHADWICK - UPPER & LOWER SIDE RAIL & GUARDRAIL

SKU#10002487006/10002488006/10002485007  
SKU#10002487003/10002488003/10002485003  
SKU#10002485006  
SKU#10002487007/10002488007/10002485008

## STEP 2

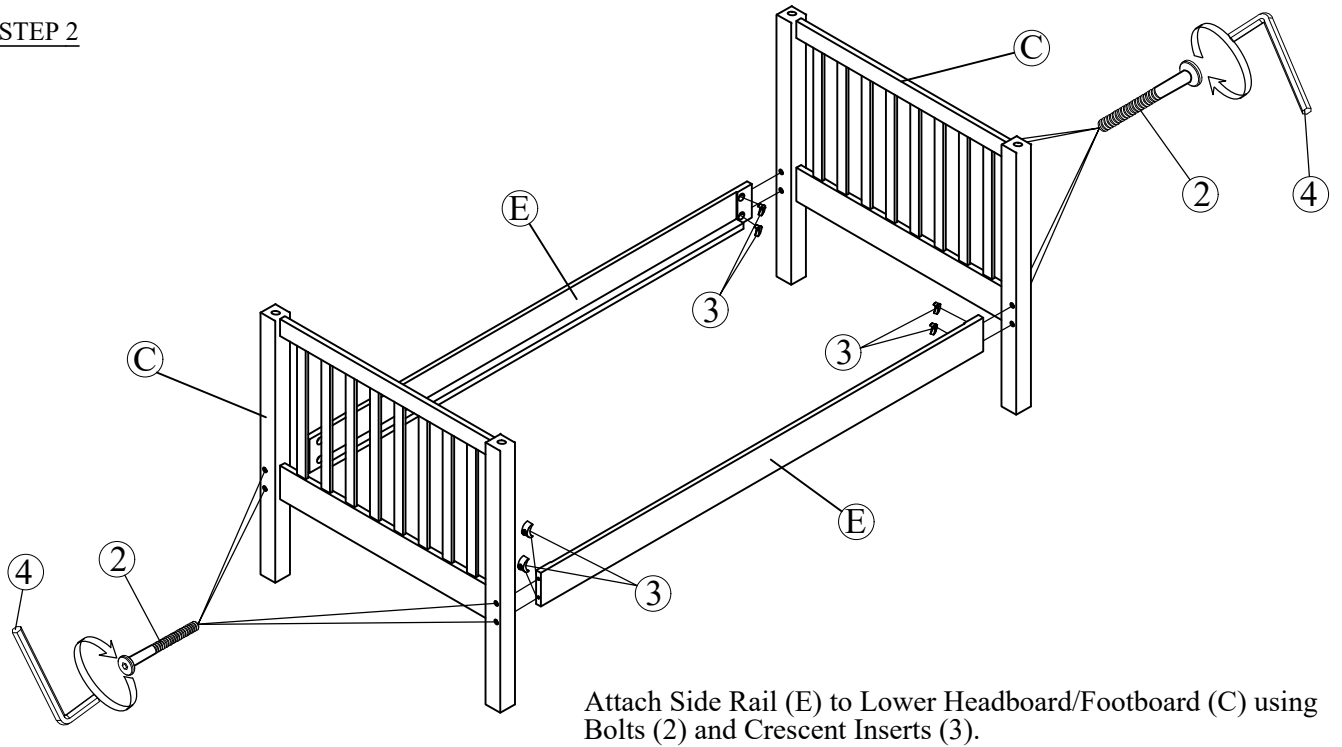

## STEP 3

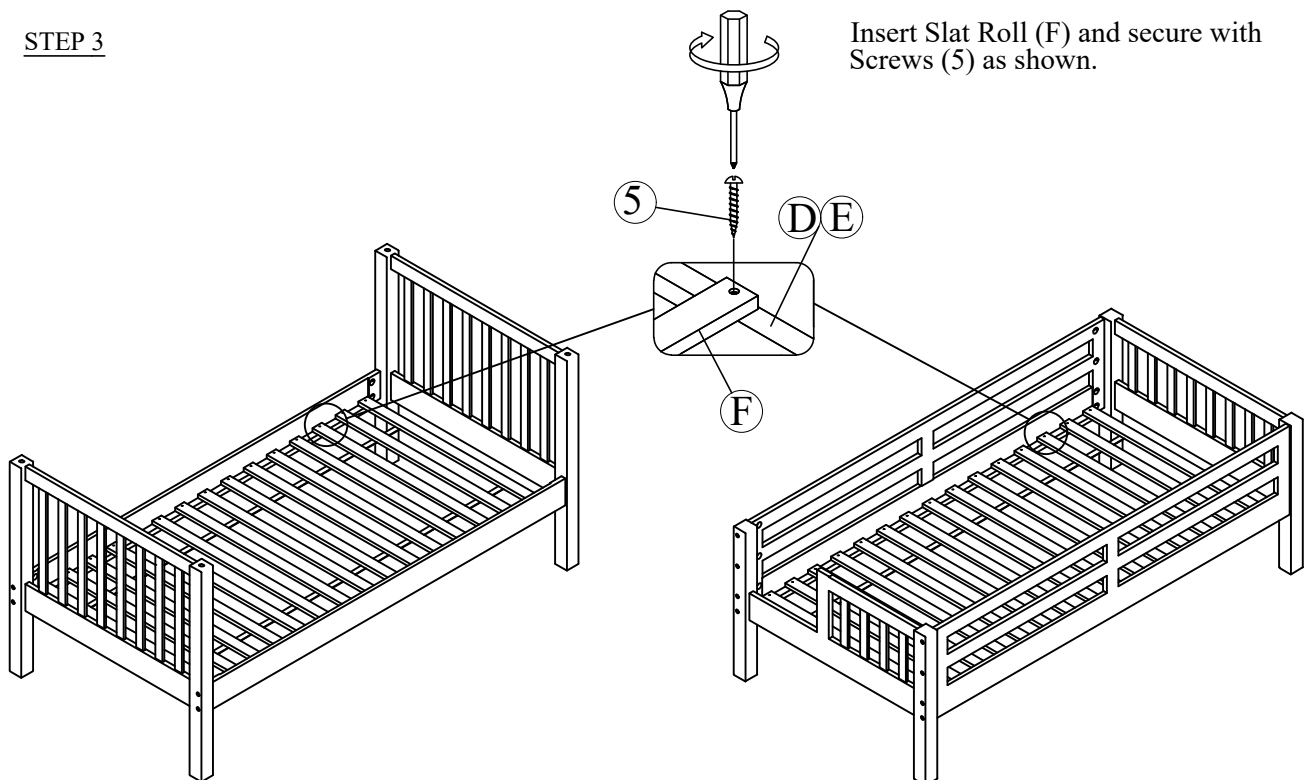

## Hardware Pack Location(s):

ITEM: 1012/1013/1014-77  
ITEM: 1012/1013/1014-79  
ITEM: 1012/1013/1014-82

CHADWICK - TWIN/TWIN UPPER HBFB  
CHADWICK - TWIN SLAT ROLL (15PCS/SET PER BOX)  
CHADWICK - UPPER & LOWER SIDE RAIL & GUARDRAIL

SKU#10002487006/10002488006/10002485007  
SKU#10002485006  
SKU#10002487007/10002488007/10002485008

# Assembly Instructions

**BOB'S**  
Discount Furniture.

ITEM: 1012/1013/1014-77  
ITEM: 1012/1013/1014-78  
ITEM: 1012/1013/1014-79  
ITEM: 1012/1013/1014-82

CHADWICK - TWIN/TWIN UPPER HBFB  
CHADWICK - TWIN/TWIN LOWER HBFB  
CHADWICK - TWIN SLAT ROLL (15PCS/SET PER BOX)  
CHADWICK - UPPER & LOWER SIDE RAIL & GUARDRAIL

SKU#10002487006/10002488006/10002485007  
SKU#10002487003/10002488003/10002485003  
SKU#10002485006  
SKU#10002487007/10002488007/10002485008

## STEP 4

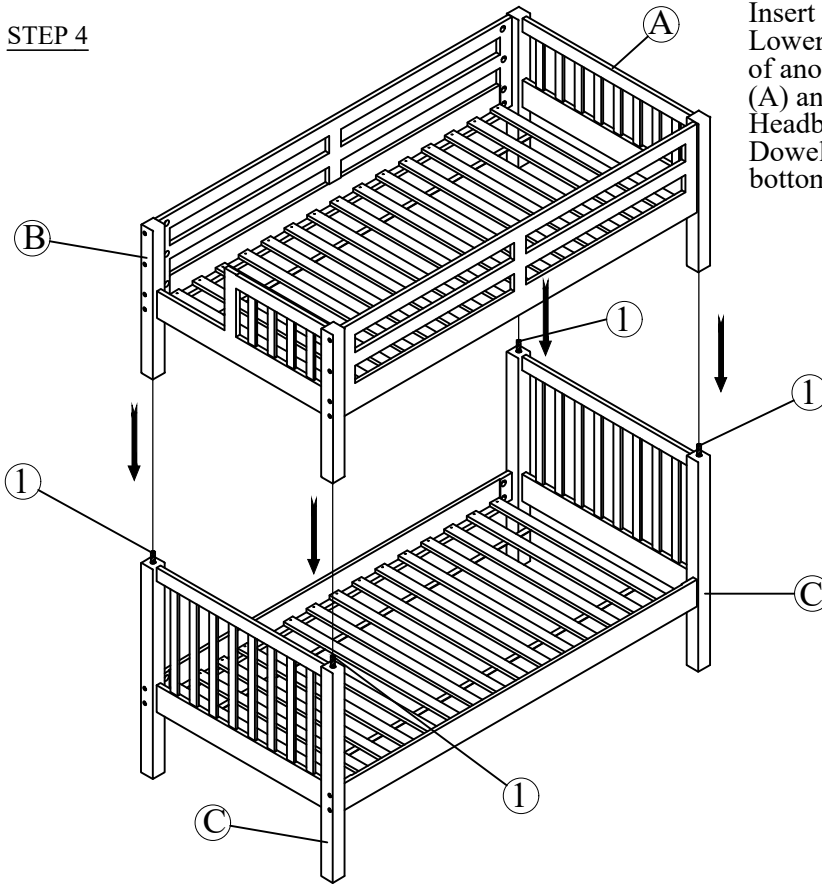

Insert Metal Dowels (1) into the tops of the Lower Headboard/Footboard (C). With the help of another individual, stack the Upper Headboard (A) and Upper Footboard (B) onto the Lower Headboard/Footboard (C) and place the Metal Dowels (1) into the pre-drilled holes on the bottom of the legs.

OPTION A - LEFT

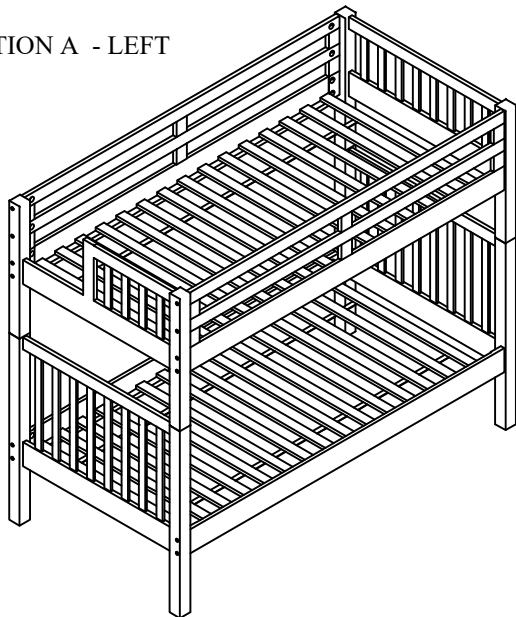

OPTION B - RIGHT

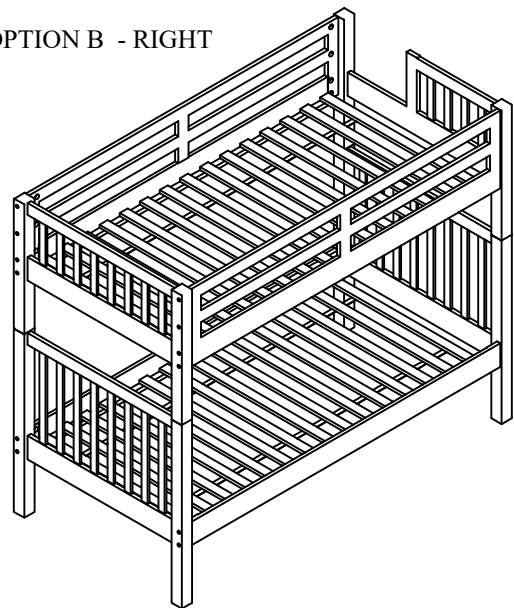

## Hardware Pack Location(s):

ITEM: 1012/1013/1014-77  
ITEM: 1012/1013/1014-79  
ITEM: 1012/1013/1014-82

CHADWICK - TWIN/TWIN UPPER HBFB  
CHADWICK - TWIN SLAT ROLL (15PCS/SET PER BOX)  
CHADWICK - UPPER & LOWER SIDE RAIL & GUARDRAIL

SKU#10002487006/10002488006/10002485007  
SKU#10002485006  
SKU#10002487007/10002488007/10002485008

# Assembly Instructions

**BOB'S**  
Discount Furniture.

ITEM: 1012/1013/1014-77  
ITEM: 1012/1013/1014-78  
ITEM: 1012/1013/1014-79  
ITEM: 1012/1013/1014-82

CHADWICK - TWIN/TWIN UPPER HBFB  
CHADWICK - TWIN/TWIN LOWER HBFB  
CHADWICK - TWIN SLAT ROLL (15PCS/SET PER BOX)  
CHADWICK - UPPER & LOWER SIDE RAIL &  
GUARDRAIL

SKU#10002487006/10002488006/10002485007  
SKU#10002487003/10002488003/10002485003  
SKU#10002485006  
SKU#10002487007/10002488007/10002485008

## OPTION A - LEFT

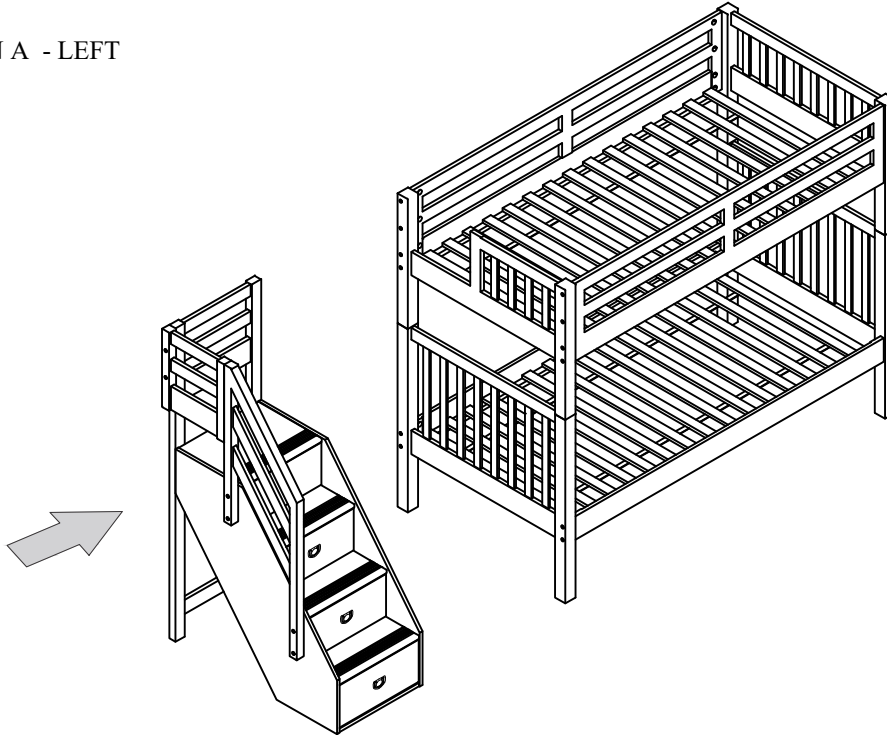

## OPTION B - RIGHT

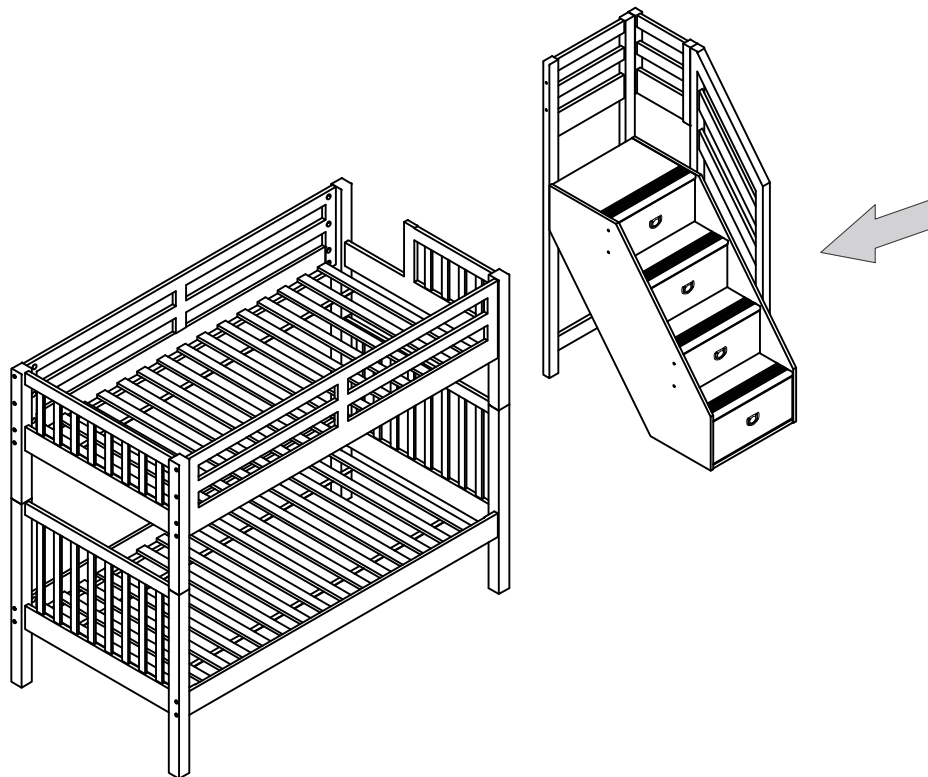

### Hardware Pack Location(s):

ITEM: 1012/1013/1014-77  
ITEM: 1012/1013/1014-79  
ITEM: 1012/1013/1014-82

CHADWICK - TWIN/TWIN UPPER HBFB  
CHADWICK - TWIN SLAT ROLL (15PCS/SET PER BOX)  
CHADWICK - UPPER & LOWER SIDE RAIL &  
GUARDRAIL

SKU#10002487006/10002488006/10002485007  
SKU#10002485006  
SKU#10002487007/10002488007/10002485008

5 of 5

MADE IN VIETNAM



**WARNING: TO HELP PREVENT SERIOUS OR FATAL INJURIES FROM ENTRAPMENT OR FALLS:**

---

- Never allow a child under 6 years on upper bunk.
- Always use the recommend size mattress or mattress support, or both, to help prevent the likelihood of entrapment or falls.
- Use only mattress which is 74-75" long and 37-1/2-38-1/2" wide on on twin size upper/lower bunk.
- Ensure thickness of mattress and foundation combined does not exceed 9" and mattress is at least 5" below upper edge of guardrails.
- Always use guardrails on both sides of the upper bunk.
- If the bunk bed will be placed next to a wall, the guardrail that runs the full length of the bed should be placed against the wall to prevent entrapment between the bed and the wall.
- Prohibit horseplay on or under bed(s) and prohibit jumping on the bed.
- Prohibit more than one person on the upper bunk.
- Use staircase for entering and leaving upper bunk.
- Maximum total weight is not to exceed 300lbs on the upper bunk.
- Periodically check and ensure that the guardrail, staircase, and other components are in their proper position free from damage, and that all connectors are tight.
- Do not use substitute parts. Replacement parts, including additional guardrails, may be obtained from our customer service department.
- Use of water or sleep flotation mattress is prohibited
- Use of a night light may provide added safety precaution for child using the upper bunk.
- Follow the information on the warnings appearing on the upper bunk end structure and on the carton.
- Keep this instruction for future reference.

**STRANGULATION HAZARD** - Never attach or hang item to any part of the bunk bed that are not designed for use with the bed; for example, but not limited to, hooks, belts and jump ropes.

**DO NOT REMOVE THIS LABEL FROM THE BED, KEEP THIS INSTRUCTION FOR FUTURE REFERENCE**

**NOTICE:**

These bunk beds are made with slats to support a standard inner coil mattress. Any all-foam mattresses without support are not recommended to use with this bed. The support system and bunk bed meet or exceeds all ASTM CPSC National Bunk Bed Safety Standards.

If you wish to use an all-foam mattress, you will need to purchase and place support over the slat system to support the all foam mattress. Bunk support panels should be the approximate size of the mattress and approximately 3/8" thick and made of plywood, MDF, or any other solid material.

# Assembly Instructions

**BOB'S**  
Discount Furniture.

ITEM: 1012/1013/1014-81 CHADWICK - 2PCS FULL EXTENSION KITS,  
15PCS FULL SLAT ROLL, 1PC CENTER SUPPORT  
& 4 PCS SUPPORT LEGS



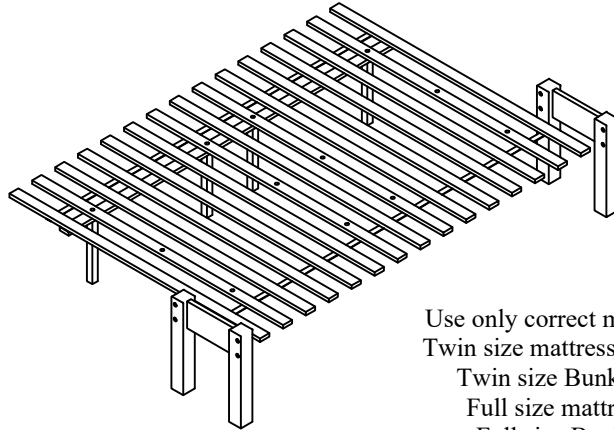

SKU#10002487001/10002488001/  
1002485001









Use only correct mattress dimensions and Bunkie board:  
Twin size mattress-74" - 75" long and 37.5" - 38.5" wide  
Twin size Bunkie board - 74" long and 37.5" wide  
Full size mattress-74\*-75"long and 53"-54"wide  
Full size Bunkie board- 74" long and 53" wide

**⚠ WARNING:** To avoid serious personal injury:

- Carefully and strictly follow assembly instructions. Improper assembly of furniture can result in structural failure, instability of the product, or tip-over.
- Monitor and carefully control the assembly components. These include small parts and hardware that may present a choking hazard to small children. Bob's furniture should be assembled only by responsible adults and children should not be involved in the assembly process.
- Where provided, wall mounting hardware should always be used as prescribed in these instructions to anchor furniture to walls. Proper use of the wall mounting hardware can significantly reduce the potential for furniture tip-over and crushing injuries.

Code	Parts	Qty
A	Extension 	2pcs
B	Full Slat Roll 	1set
C	Center Support 	1pc
D	Support Leg 	4pcs

Code	Hardware (Packed In Side Rail Carton)	Qty
2	Bolt Ø1/4"*15*4-1/4" 	4pcs
3	Crescent Insert 1/4" 	4pcs

Code	Hardware (Packed In Full Bed Extension Kit Carton)	Qty
4	Allen Key 4mm 	2pcs
5	Screw M4*1-1/4" 	30pcs
6	Metal Connection 110*77*2.5mm 	2pcs
7	Hole Cover Ø1/4"*15*5/8" 	8pcs
8	Bolt Ø1/4"*15*2-1/4" 	12pcs

TOOLS REQUIRED ( NOT PROVIDED )

Phillips Screwdriver 

## Hardware Pack Location(s):

ITEM: 1012/1013/1014-81 CHADWICK - 2PCS FULL EXTENSION KITS,  
15PCS FULL SLAT ROLL, 1PC CENTER SUPPORT  
& 4 PCS SUPPORT LEGS

SKU#10002487001/10002488001/  
1002485001

# Assembly Instructions

**BOB'S**  
Discount Furniture.

ITEM: 1012/1013/1014-81 CHADWICK - 2PCS FULL EXTENSION KITS,  
15PCS FULL SLAT ROLL, 1PC CENTER SUPPORT  
& 4 PCS SUPPORT LEGS

SKU#10002487001/10002488001/  
1002485001

## STEP 1

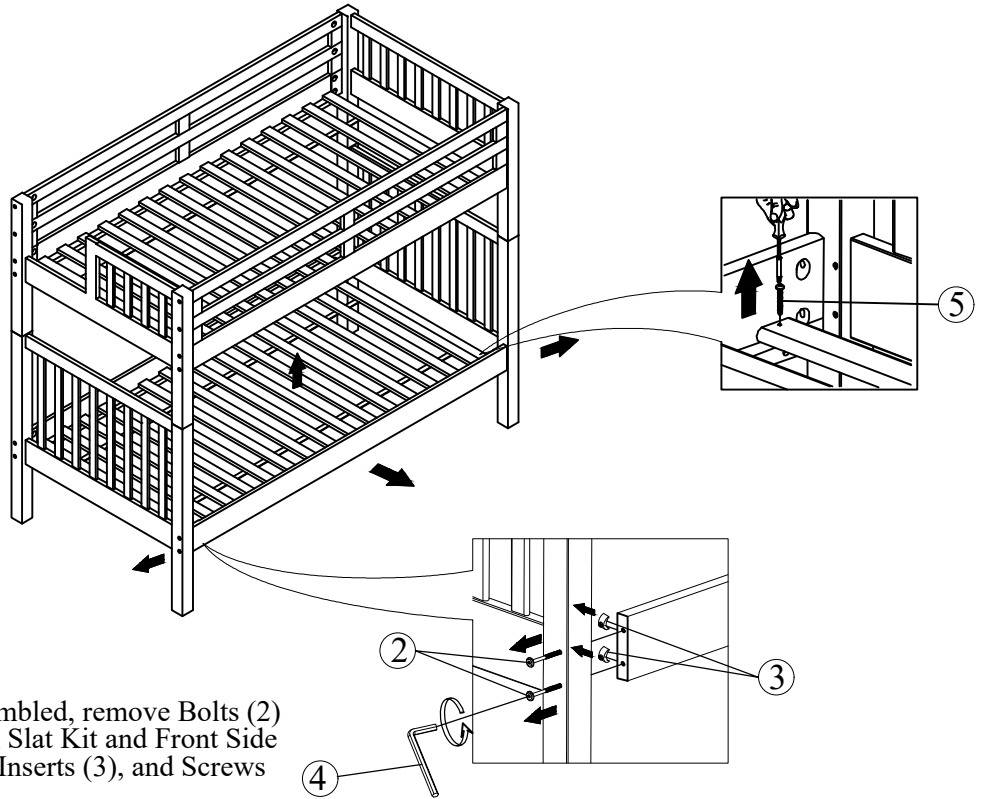

If Bunkbed was previously assembled, remove Bolts (2) and Screws (5) from the Bottom Slat Kit and Front Side Rail. Retain Bolts (2), Crescent Inserts (3), and Screws (5) for assembly.

## STEP 2

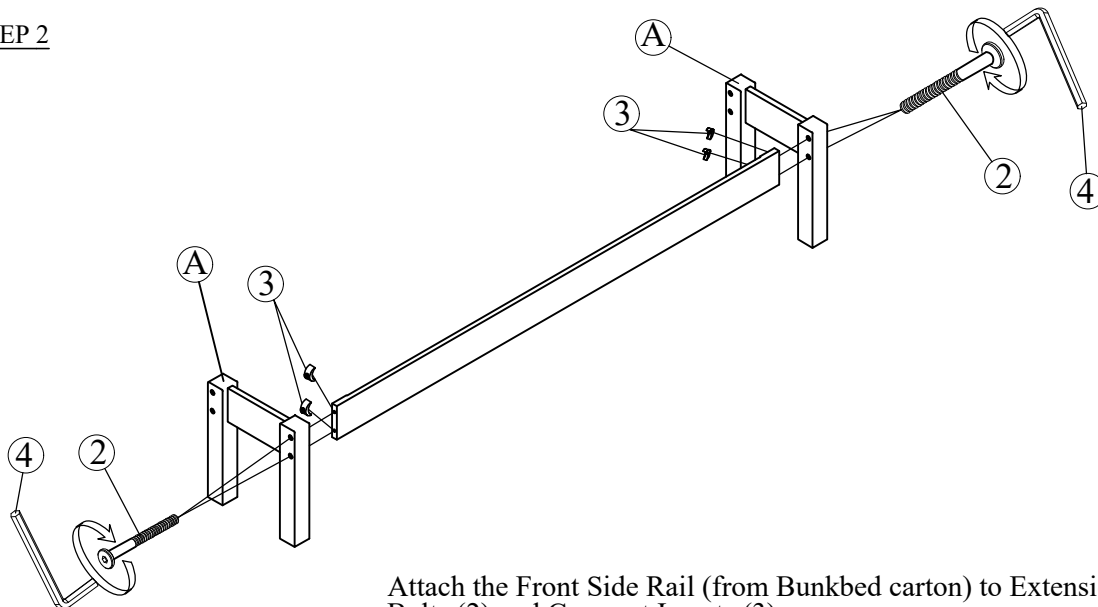

Attach the Front Side Rail (from Bunkbed carton) to Extensions (A) using Bolts (2) and Crescent Inserts (3).

## Hardware Pack Location(s):

ITEM: 1012/1013/1014-81 CHADWICK - 2PCS FULL EXTENSION KITS,  
15PCS FULL SLAT ROLL, 1PC CENTER SUPPORT  
& 4 PCS SUPPORT LEGS

SKU#10002487001/10002488001/  
1002485001

# Assembly Instructions

**BOB'S**  
Discount Furniture.

ITEM: 1012/1013/1014-81 CHADWICK - 2PCS FULL EXTENSION KITS,  
15PCS FULL SLAT ROLL, 1PC CENTER SUPPORT  
& 4 PCS SUPPORT LEGS

SKU#10002487001/10002488001/  
1002485001

## STEP 3

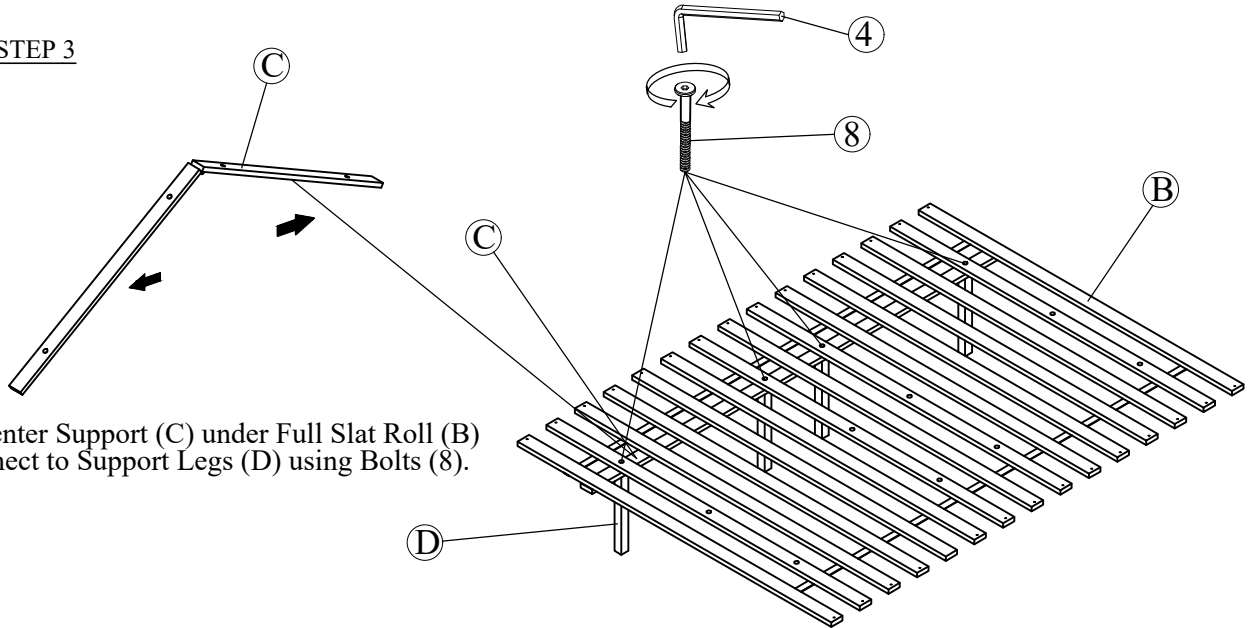

Place Center Support (C) under Full Slat Roll (B) and connect to Support Legs (D) using Bolts (8).

## STEP 4

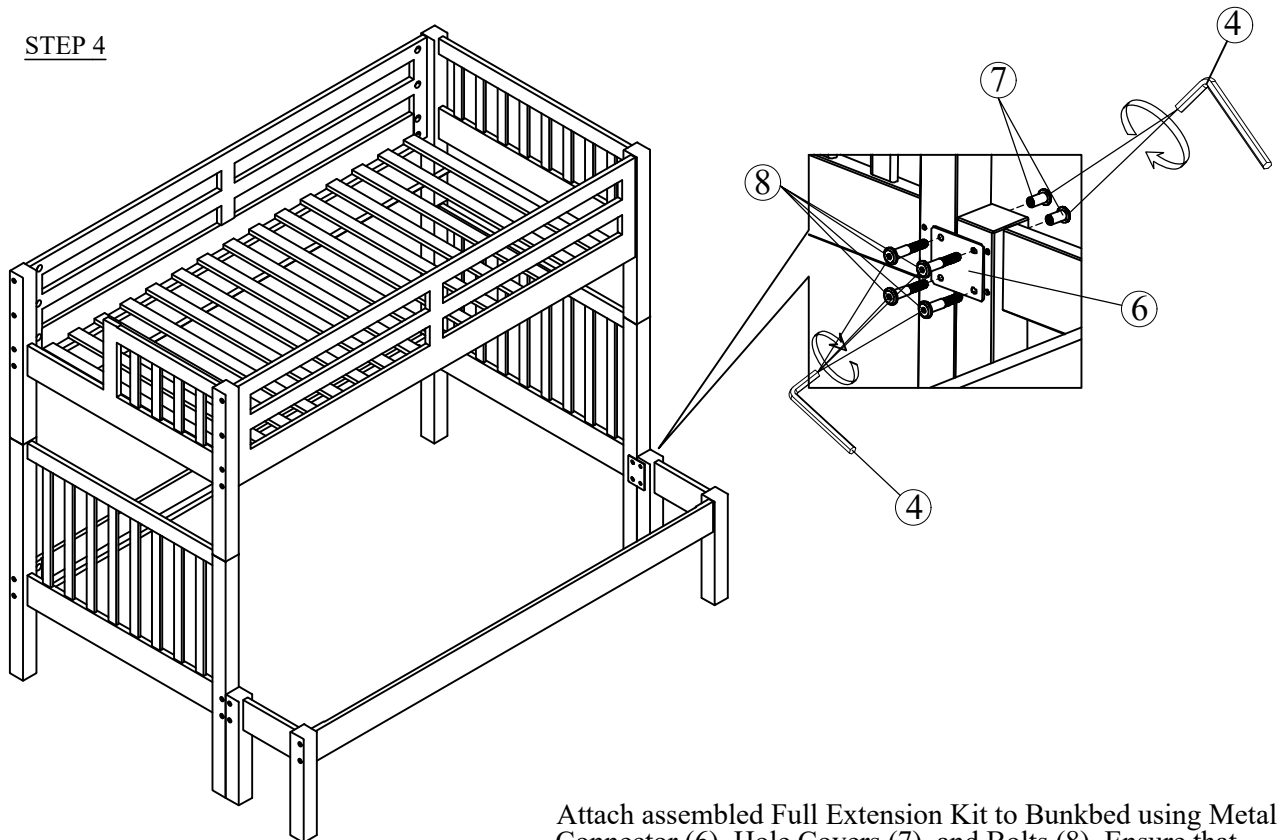

Attach assembled Full Extension Kit to Bunkbed using Metal Connector (6), Hole Covers (7), and Bolts (8). Ensure that the Metal Connector (6) is installed on the inside of the Bunkbed legs.

## Hardware Pack Location(s):

ITEM: 1012/1013/1014-81 CHADWICK - 2PCS FULL EXTENSION KITS,  
15PCS FULL SLAT ROLL, 1PC CENTER SUPPORT  
& 4 PCS SUPPORT LEGS

SKU#10002487001/10002488001/  
1002485001

# Assembly Instructions

**BOB'S**  
Discount Furniture.

ITEM: 1012/1013/1014-81 CHADWICK - 2PCS FULL EXTENSION KITS,  
15PCS FULL SLAT ROLL, 1PC CENTER SUPPORT  
& 4 PCS SUPPORT LEGS

SKU#10002487001/10002488001/  
1002485001

## STEP 5

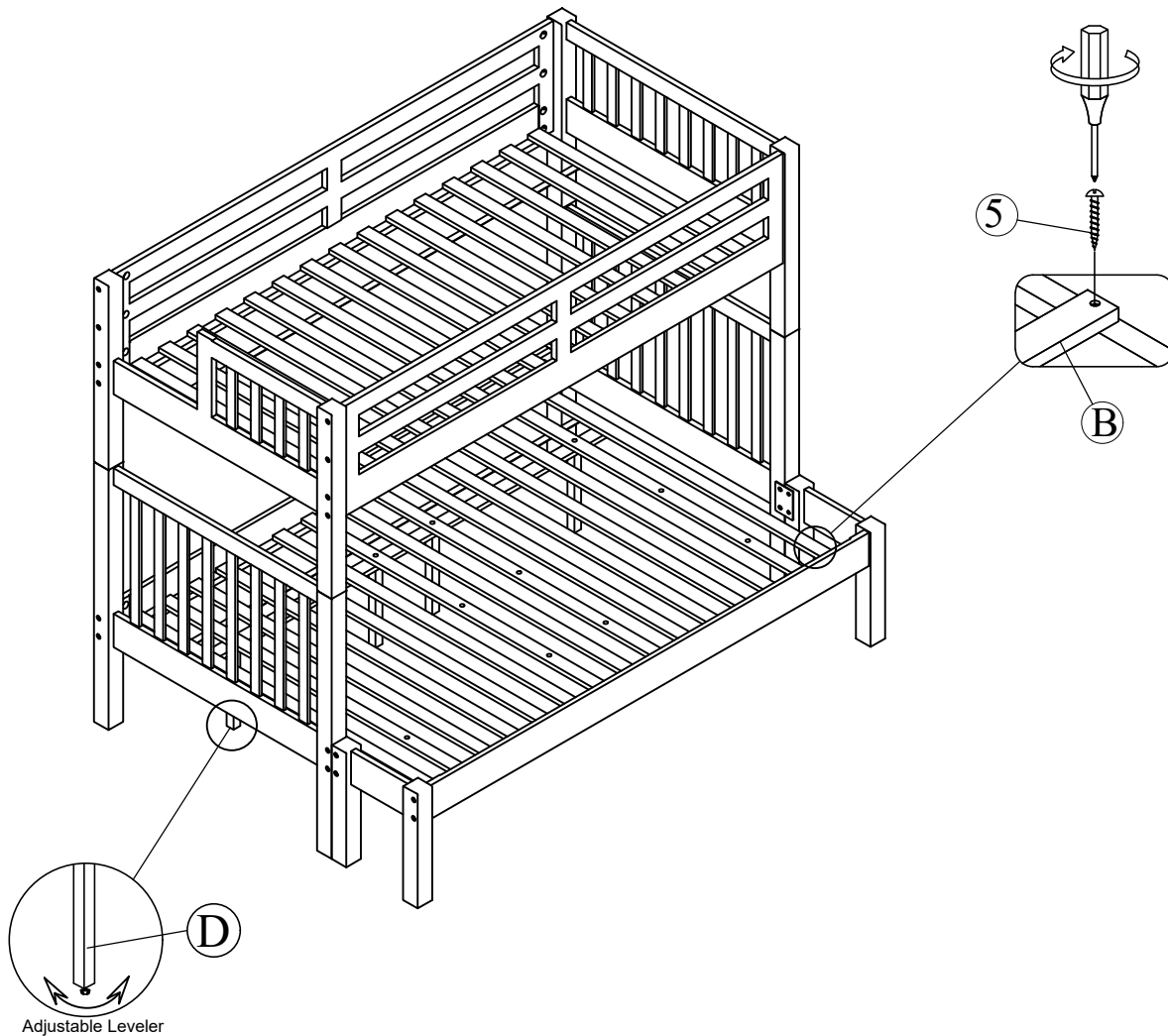

Place the assembled Full Slat Kit into the Bottom Bunkbed and secure with Screws (5).  
Use the Adjustable Levelers on Support Legs (D) to ensure stability.

### Hardware Pack Location(s):

ITEM: 1012/1013/1014-81 CHADWICK - 2PCS FULL EXTENSION KITS,  
15PCS FULL SLAT ROLL, 1PC CENTER SUPPORT  
& 4 PCS SUPPORT LEGS

SKU#10002487001/10002488001/  
1002485001

4 of 4

MADE IN VIETNAM



**WARNING: TO HELP PREVENT SERIOUS OR FATAL INJURIES FROM ENTRAPMENT OR FALLS:**

---

- Never allow a child under 6 years on upper bunk.
- Always use the recommend size mattress or mattress support, or both, to help prevent the likelihood of entrapment or falls.
- Use only mattress which is 74-75" long and 37-1/2-38-1/2" wide on on twin size upper bunk,74"-75" long and 53"-54" wide on full size lower bunk.
- Ensure thickness of mattress and foundation combined does not exceed 9" and mattress is at least 5" below upper edge of guardrails.
- Always use guardrails on both sides of the upper bunk.
- If the bunk bed will be placed next to a wall, the guardrail that runs the full length of the bed should be placed against the wall to prevent entrapment between the bed and the wall.
- Prohibit horseplay on or under bed(s) and prohibit jumping on the bed.
- Prohibit more than one person on the upper bunk.
- Use staircase for entering and leaving upper bunk.
- Maximum total weight is not to exceed 300lbs on the upper bunk.
- Periodically check and ensure that the guardrail, staircase, and other components are in their proper position free from damage, and that all connectors are tight.
- Do not use substitute parts. Replacement parts, including additional guardrails, may be obtained from our customer service department.
- Use of water or sleep flotation mattress is prohibited
- Use of a night light may provide added safety precaution for child using the upper bunk.
- Follow the information on the warnings appearing on the upper bunk end structure and on the carton.
- Keep this instruction for future reference.

**STRANGULATION HAZARD** - Never attach or hang item to any part of the bunk bed that are not designed for use with the bed; for example, but not limited to, hooks, belts and jump ropes.

**DO NOT REMOVE THIS LABEL FROM THE BED, KEEP THIS INSTRUCTION FOR FUTURE REFERENCE**

**NOTICE:**

These bunk beds are made with slats to support a standard inner coil mattress. Any all-foam mattresses without support are not recommended to use with this bed. The support system and bunk bed meet or exceeds all ASTM CPSC National Bunk Bed Safety Standards.

If you wish to use an all-foam mattress, you will need to purchase and place support over the slat system to support the all foam mattress. Bunk support panels should be the approximate size of the mattress and approximately 3/8" thick and made of plywood, MDF, or any other solid material.

# Assembly Instructions

ITEM: 1012/1013/1014-05A





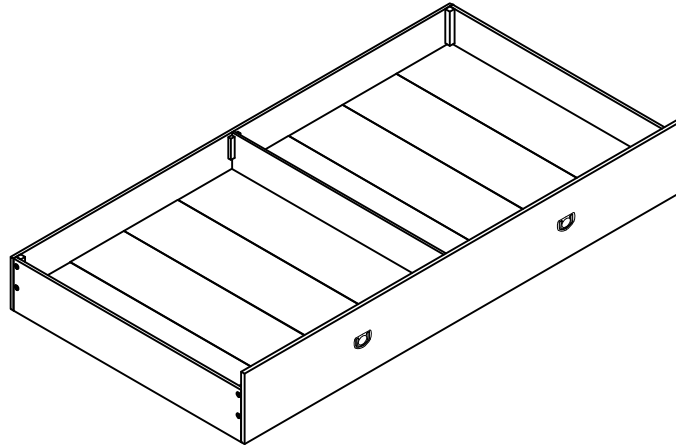

CHADWICK - TRUNDLE



SKU#10002487005/10002488005/10002485005



**⚠ WARNING:** To avoid serious personal injury:

- Carefully and strictly follow assembly instructions. Improper assembly of furniture can result in structural failure, instability of the product, or tip-over.
- Monitor and carefully control the assembly components. These include small parts and hardware that may present a choking hazard to small children. Bob's furniture should be assembled only by responsible adults and children should not be involved in the assembly process.
- Where provided, wall mounting hardware should always be used as prescribed in these instructions to anchor furniture to walls. Proper use of the wall mounting hardware can significantly reduce the potential for furniture tip-over and crushing injuries.

Code	Parts	Qty
A	Front Panel 	1pc
B	Back Panel 	1pc
C	Side Panel 	2pcs
D	Divider Panel 	1pc
E	Bottom Panel A 	6pcs
F	Bottom Panel B 	2pcs

Code	Hardware	Qty
1	Bolt Ø1/4"*15*3/4" 	8pcs
2	Allen Key 4mm 	1pc
3	Screw M4*1-1/4" 	12pcs

**TOOLS REQUIRED ( NOT PROVIDED )**

Phillips Screwdriver 

**Hardware Pack Location(s):**

ITEM: 1012/1013/1014-05A

CHADWICK - TRUNDLE

SKU#10002487005/10002488005/10002485005

# Assembly Instructions

**BOB'S**  
Discount Furniture.

ITEM: 1012/1013/1014-05A

CHADWICK - TRUNDLE

SKU#10002487005/10002488005/10002485005

## STEP 1

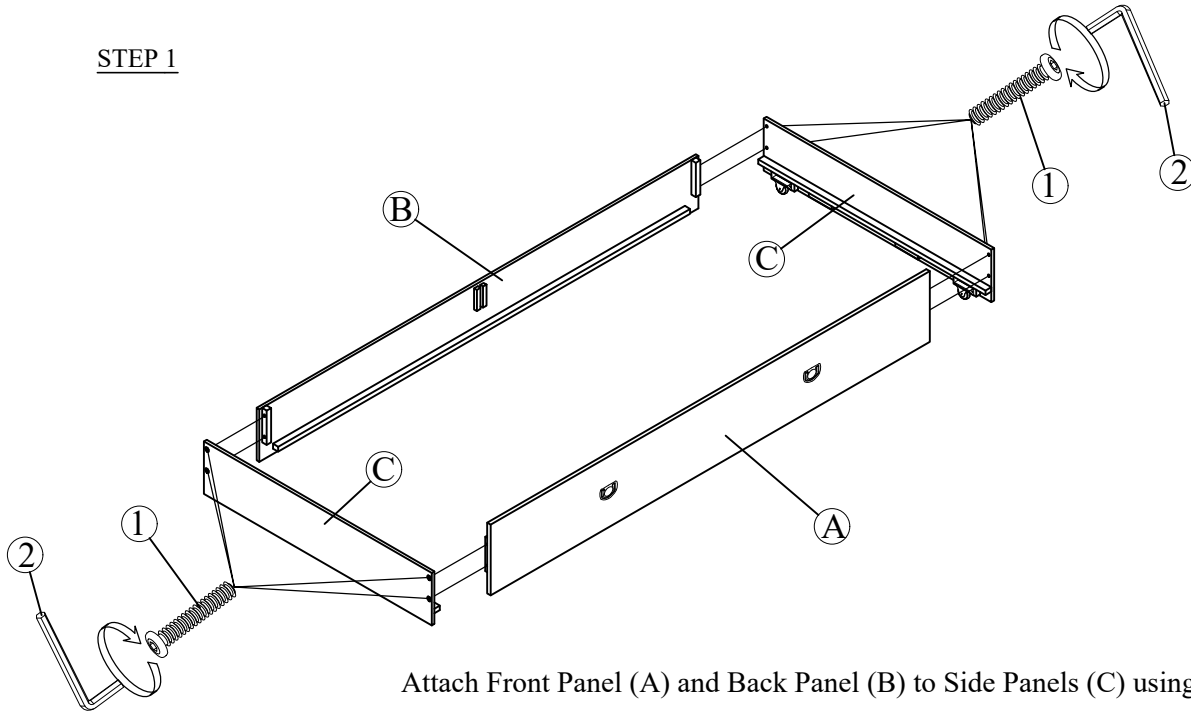

Attach Front Panel (A) and Back Panel (B) to Side Panels (C) using Bolts (1).

## STEP 2

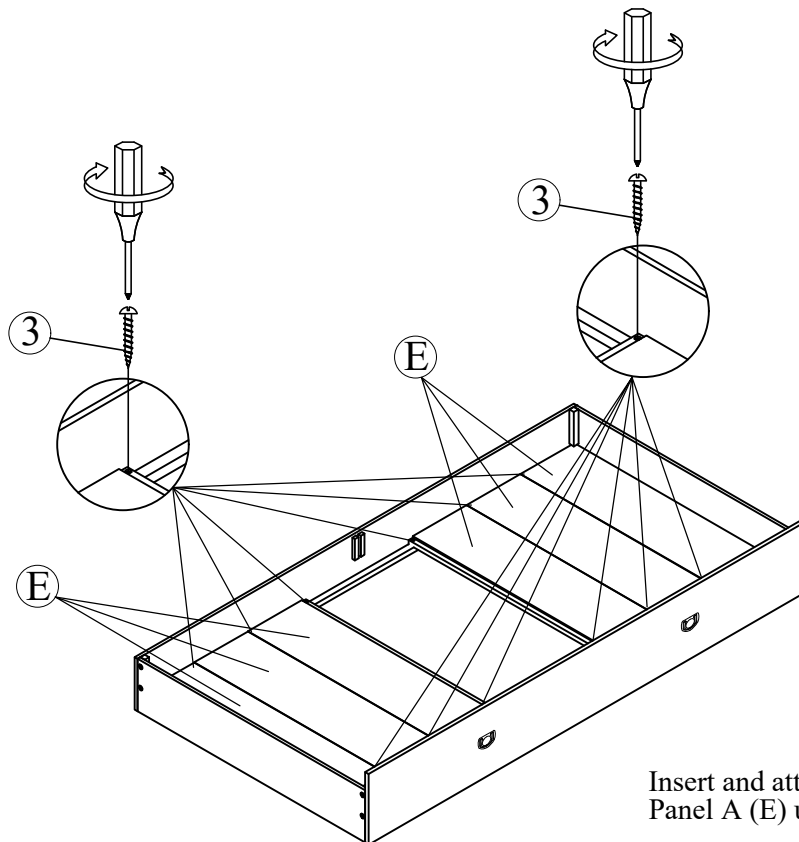

Insert and attach the 6pcs of Bottom Panel A (E) using Screws (3) as shown.

## Hardware Pack Location(s):

ITEM: 1012/1013/1014-05A

CHADWICK - TRUNDLE

SKU#10002487005/10002488005/10002485005

# Assembly Instructions

**BOB'S**  
Discount Furniture.

ITEM: 1012/1013/1014-05A

CHADWICK - TRUNDLE

SKU#10002487005/10002488005/10002485005

## STEP 3

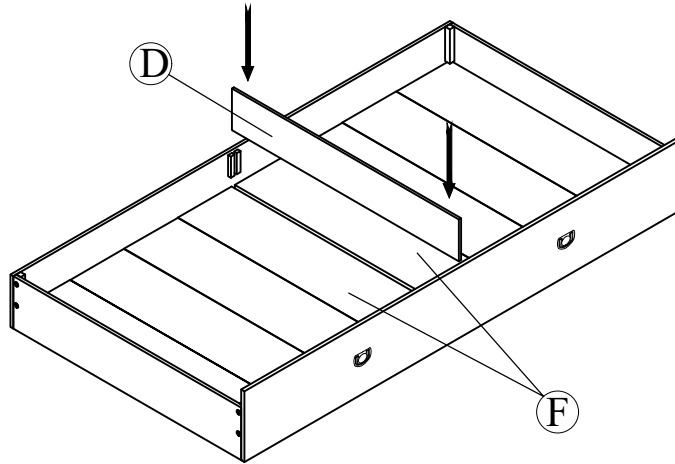

Place 2pcs of Bottom Panel B (F) into the center and then insert Divider Panel (D).

## COMPLETE

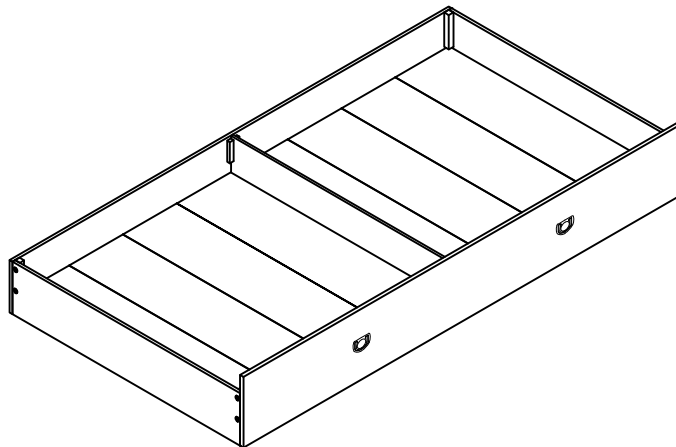

## Hardware Pack Location(s):

ITEM: 1012/1013/1014-05A

CHADWICK - TRUNDLE

SKU#10002487005/10002488005/10002485005