

Assembly Instruction For CASCADE TWIN PANEL BED 20093393 / 20093398

⚠WARNING: To avoid serious personal injury:

- Carefully and strictly follow assembly instructions. Improper assembly of furniture can result in structural failure, instability of the product, or tip-over.
- Monitor and carefully control the assembly components. These include small parts and hardware that may present a choking hazard to small children. Bob's furniture should be assembled only by responsible adults and children should not be involved in the assembly process.
- Where provided, wall mounting hardware should always be used as prescribed in these instructions to anchor furniture to walls. Proper use of the wall mounting hardware can significantly reduce the potential for furniture tip-over and crushing injuries.

PART LIST				HARDWARE LIST			
NO.	PART DESC	CODE	Q'TY	NO.	HARDWARE DESC	CODE	Q'TY
A	HEADBOARD	B-14820-6-THF B-14820-8-THF	1	1	JCBB BOLT (1/4" x 1" 5/8)	PB-14820-KBHW	8
B/L	LEFT HEADBOARD LEG	PB-14820-6-HBLEG1 PB-14820-8-HBLEG1	1	2	SPRING WASHER (1/4")		8
B/R	RIGHT HEADBOARD LEG	PB-14820-6-HBLEG2 PB-14820-8-HBLEG2	1	3	FLAT WASHER (1/4" x 5/8")		8
C	HEADBOARD BOTTOM STRETCHER	PB-14820-THSTR	1	4	ALLEN KEY(5/32")		1
D	FOOTBOARD	B-14820-6-THF B-14820-8-THF	1	5	CSK SCREW (#4 x 1"1/4)		8
E	SLAT	PB-14820-TBSLT	4	6	SCREW-DRIVER(NOT PROVIDED)		
F	SLAT SUPPORT LEG	PB-14820-BDSPL	4	*HARDWARE LOCATED IN LEG BOX			
G	SIDE RAIL	B-14820-6-TFR B-14820-8-TFR	2				

⚠ Only tighten all bolts when all bolts aligned with bolt inserts.

STEP 1

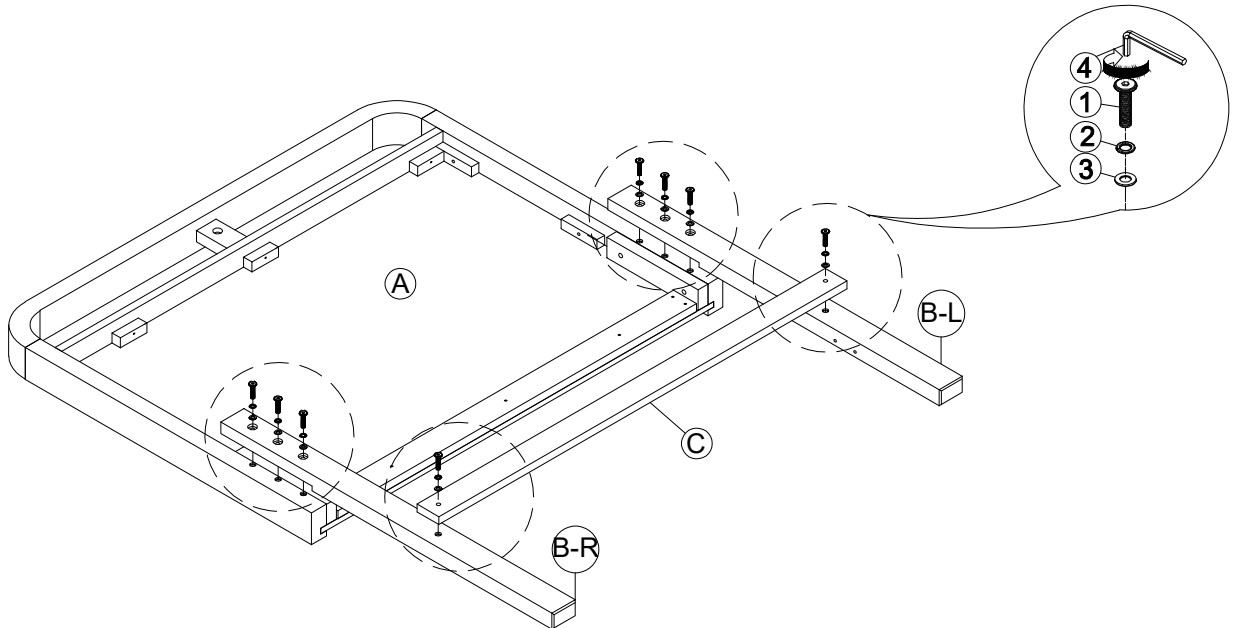

Assembly Instruction For CASCADE TWIN PANEL BED 20093393 / 20093398

STEP 2

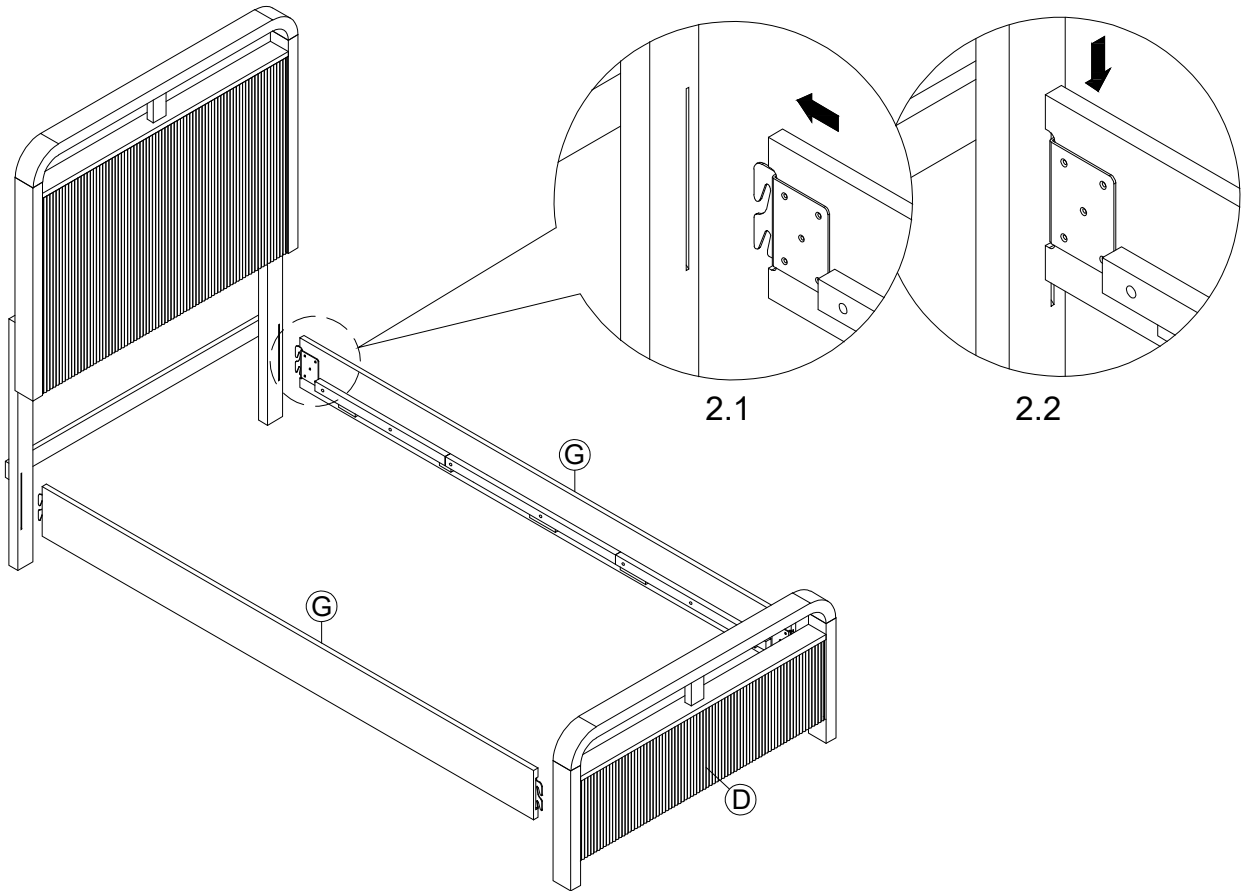

COMPLETED

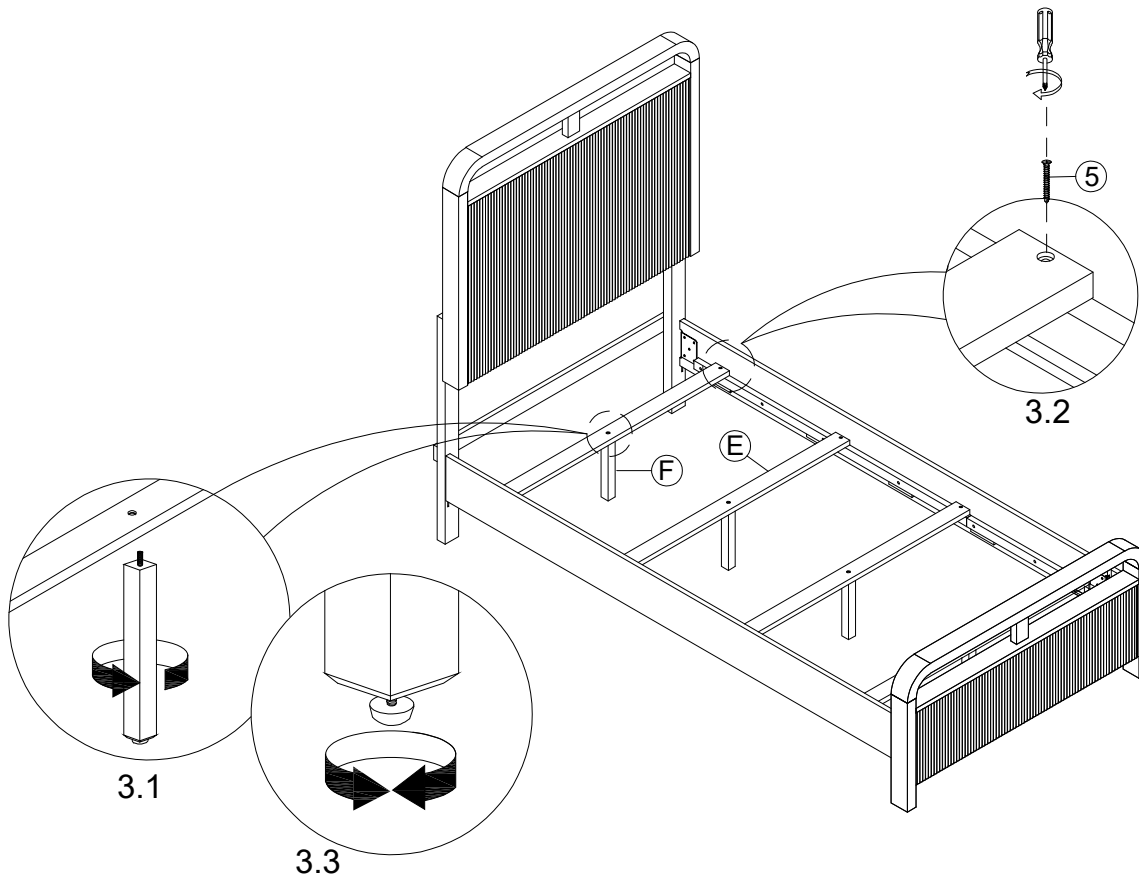



WARNING: To avoid serious personal injury:

- Carefully and strictly follow assembly instructions. Improper assembly of furniture can result in structural failure, instability of the product, or tip-over.
- Monitor and carefully control the assembly components. These include small parts and hardware that may present a choking hazard to small children. Bob's furniture should be assembled only by responsible adults and children should not be involved in the assembly process.
- Where provided, wall mounting hardware should always be used as prescribed in these instructions to anchor furniture to wall. Proper use of the wall mounting hardware can significantly reduce the potential for furniture tip-over and crushing injuries.