



















ASSEMBLY INSTRUCTION BETTIE FULL UPH BED

Caution : Please read instructions thoroughly before unpacking assembly parts. Sharp, exposed staple tips cause injury, therefore for your protection, please remove any exposed staples used in packing.

1. We recommend that you should assemble this product with the assistance of another person; this will make assembly easier, and will help to eliminate damage to the product or injury to persons during assembly.
2. Be sure to check all packing materials carefully for small parts that may have come loose inside the carton during shipment.
3. Please do not over tighten screws or bolts.
4. Please put all parts on a non-abrasive floor before assembly, and follow the assembly step to assemble your newly purchased product correctly and efficiently.

PART LIST FOR FULL BED				
NO		PART DESC	PART CODE	QTY
A		Headboard		1pcs
B		Footboard		1pcs
C		Side Rail		4pcs
D		Headboard Left & Right Support Legs (2 PCS/SET)	PUB-4730-HBLEG	2pcs
E		Roll Slat (PCE)	PUB-4730-FBSLT	12pcs
F		Side Rail Leg (PCE)		2pcs
G		Base Leg Strecher	PUB-4730-FHSTR	1pcs
H		Center Rail (PCE)		2pcs
I		Support Legs (PCE)	PUB-4730-BDSPL	4pcs

HARDWARE LIST FOR FULL BED				
NO		HARDWARE DESC	HARDWARE CODE	QTY
1		CSK Screw 32mm		24pcs
2		JCBC M6 x 30		16pcs
3		JCBB M8 x 20		8pcs
4		Flat Washers		10pcs
5		Spring Washers	PUB-4730-KBHW	6pcs
6		L Key M6		1pcs
7		L Key M8		1pcs
8		JCBC M6 x 60		4pcs
9		Adjuster		4pcs

 Only tighten all bolts when all bolts aligned with bolt inserts

ASSEMBLY INSTRUCTION FOR FULL BED

STEP 1

Unwrap the black non-woven fabric on the back of headboard and take out all the parts out.

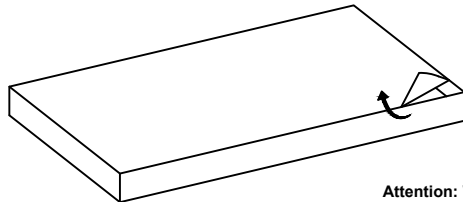

Attention: Wrap the black non-woven fabric after take out the parts !!

BACK VIEW

STEP 2

Fix the headboard (A) with legs (D) as shown.

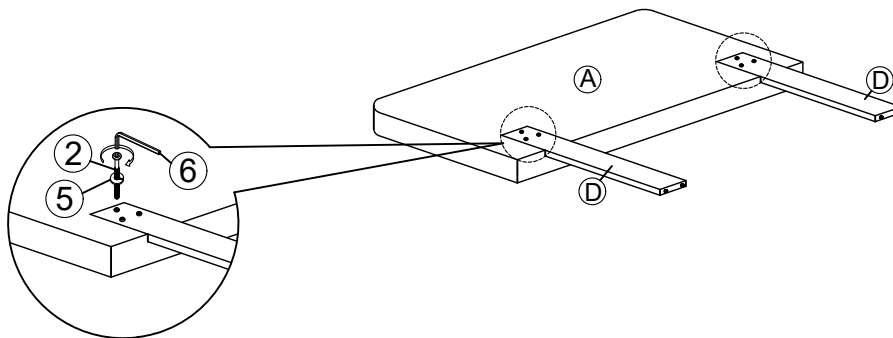

BACK VIEW

STEP 3

Attach the base leg stretcher (G) to the headbord legs (D).

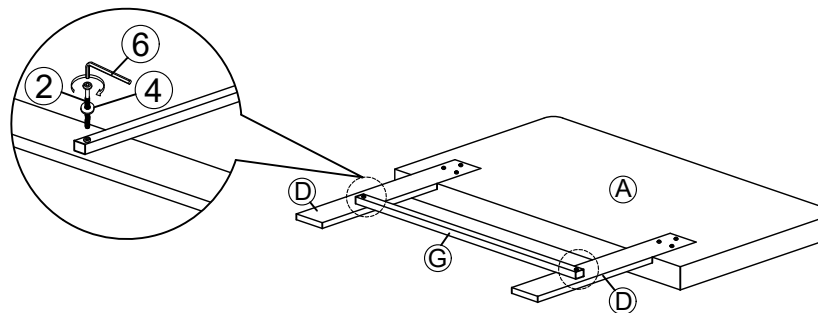

BACK VIEW

ASSEMBLY INSTRUCTION FOR FULL BED

STEP 4

Attach the JCBB Bolt (3) to the headboard legs (D) and footboard (B).

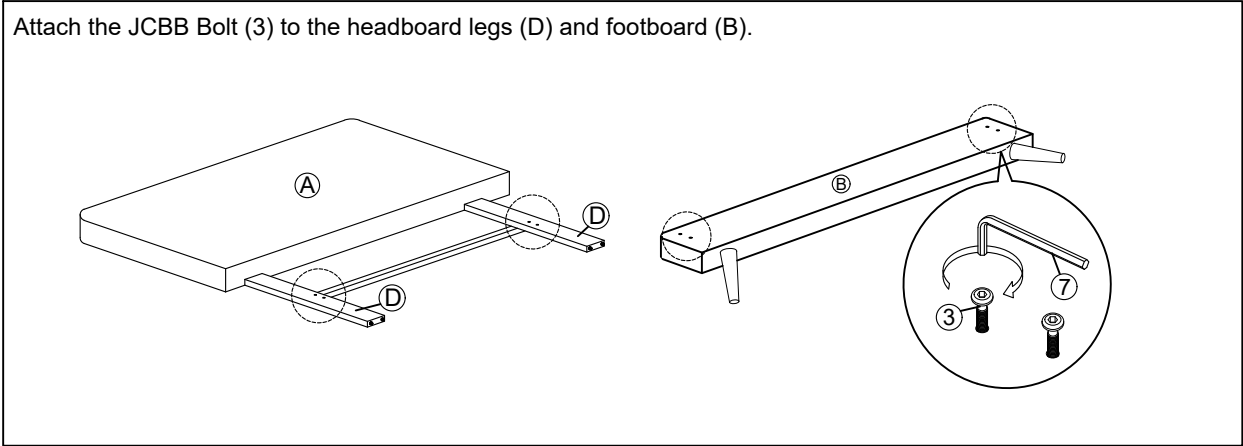

STEP 5

Attach side rail leg (F) to the side rail (C).

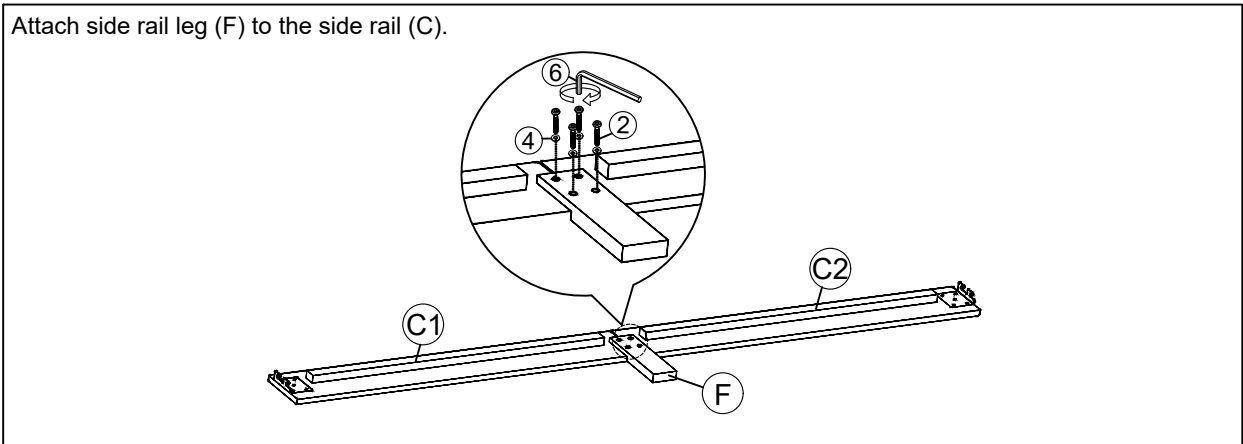

STEP 6

Attach side rail (C) to the footboard (B) by pushing the bracket down to fit it.

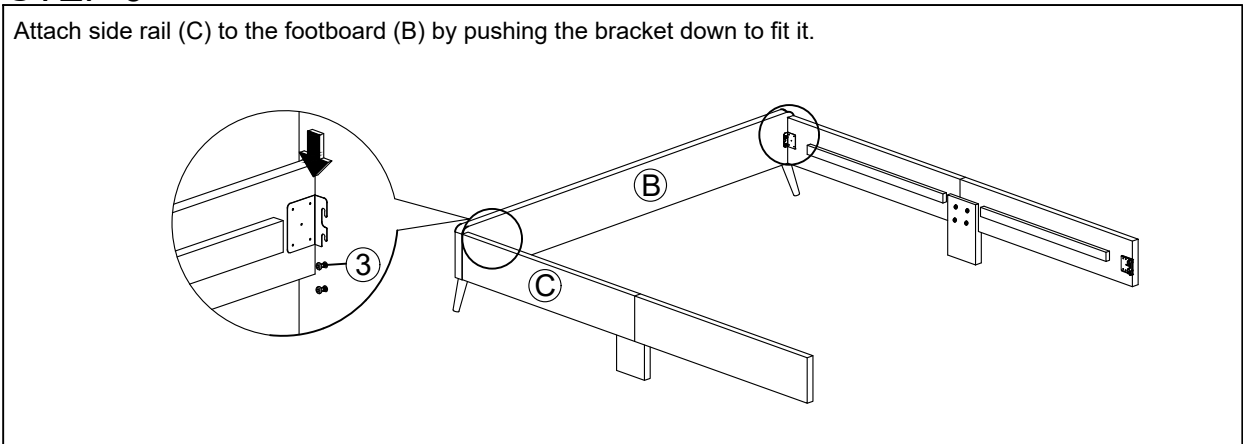

ASSEMBLY INSTRUCTION FOR FULL BED

STEP 7

Attach side rail (C) to the headboard (A) by pushing the bracket down to fit it.

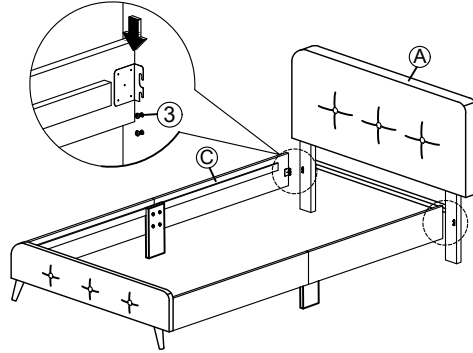

STEP 8

Attach the support legs (I) to the slats (E) and center rail (H).

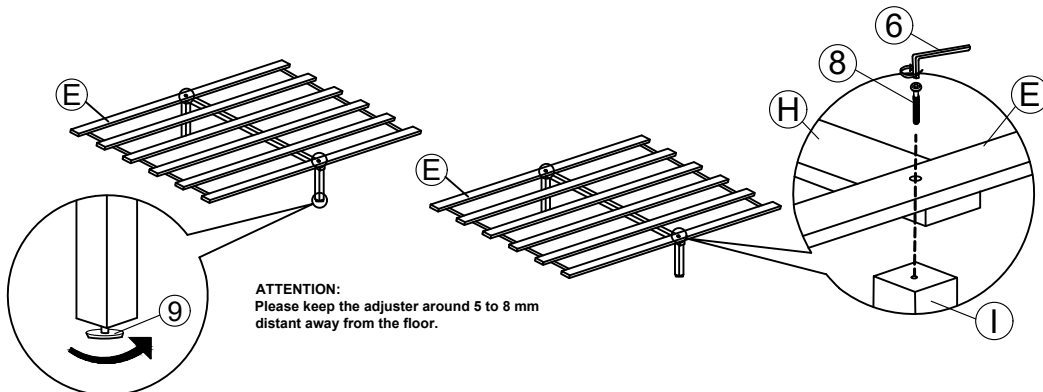

STEP 9

Tighten the 4 Corner with Allen Key (7). Install the bed slats (E) to side rail (C). Tighten the slats E) with CSK screw (1). The distance of the slats should be sufficient to obtain desirable bed stability.

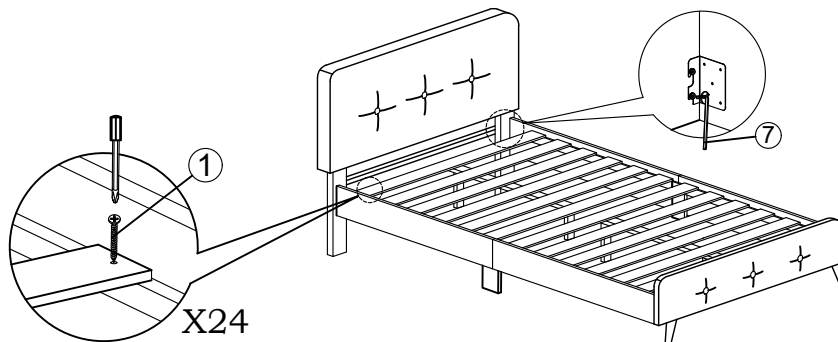

ASSEMBLY INSTRUCTION FOR FULL BED

STEP 10

Completed.

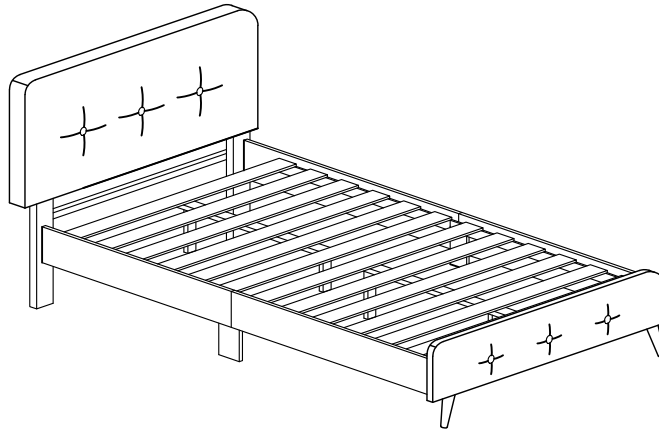

⚠ WARNING : To avoid serious personal injury :

- Carefully and strictly follow assembly instructions. Improper assembly of furniture can result in structural failure, instability of the product, or tip-over.
- Monitor and carefully control the assembly components. These include small parts and hardware that may present a choking hazard to small children. Furniture should be assembled only by responsible adults and children should not be involved in the assembly process.
- Where provided, wall mounting hardware should always be used as prescribed in these instructions to anchor furniture to walls. Proper use of the wall mounting hardware can significantly reduce the potential for furniture tip-over and crushing injuries.